

Montage handleiding
Notice de montage
Manual

EXTERIOR



INLEIDING

Hartelijk gefeliciteerd met de aanschaf van een Gardival® tuinhuis. Uw tuinhuis is vervaardigd uit kwaliteitsvol Noord-Europees gelijmd vurenhout. Hierbij vindt u de handleiding om dit tuinhuis zelf te plaatsen. Het is aan te raden deze brochure eerst aandachtig te lezen voordat u met de plaatsing begint.

Veel succes met het plaatsen van uw tuinhuis.

INTRODUCTION

Nous vous remercions pour votre achat d'un abri Gardival®. Votre abri est fait dans un bois lamellé collé avec qualité le pin du Nord. Ci-joint vous trouvez la notice de montage pour vous faciliter la pose de votre abri. Nous vous conseillons de lire d'abord cette notice avant de commencer la pose.

Nous vous souhaitons beaucoup de succès avec la pose de votre abri.

INTRODUCTION

Congratulations on your purchase of a Gardival® garden building. Your gardenhouse has been manufactured in high-quality glued Nordic pinewood. Here are the instructions to assemble your gardenhouse. We recommend reading this brochure carefully before starting the assembly of your gardenhouse.

We wish you lots of success with the assembly of your gardenhouse.

Montage handleiding
Notice de montage
Manual

EXTERIOR

met aanbouwmodule
avec élément de série



EXTERIOR

VOORBEELD EXTERIOR AFMETINGEN
 EXEMPLE EXTERIOR MESURES
 EXAMPLE EXTERIOR MEASURES
 3000 x 3000 mm
 3500* x 3500* mm
 4000* x 4000* mm

VOORBEELD EXTERIOR AFMETINGEN
 EXEMPLE EXTERIOR MESURES
 EXAMPLE EXTERIOR MEASURES
 3500* x 3000 mm / 3000 x 3500* mm
 3500* x 4000* mm / 4000* x 3500* mm
 4000* x 3000 mm / 3000 x 4000* mm

* extra paal voor opening 2760mm bij schuifdeur

* extra poteau pour ouverture 2760mm pour porte coulissant

* extra post for gap 2760mm for sliding door

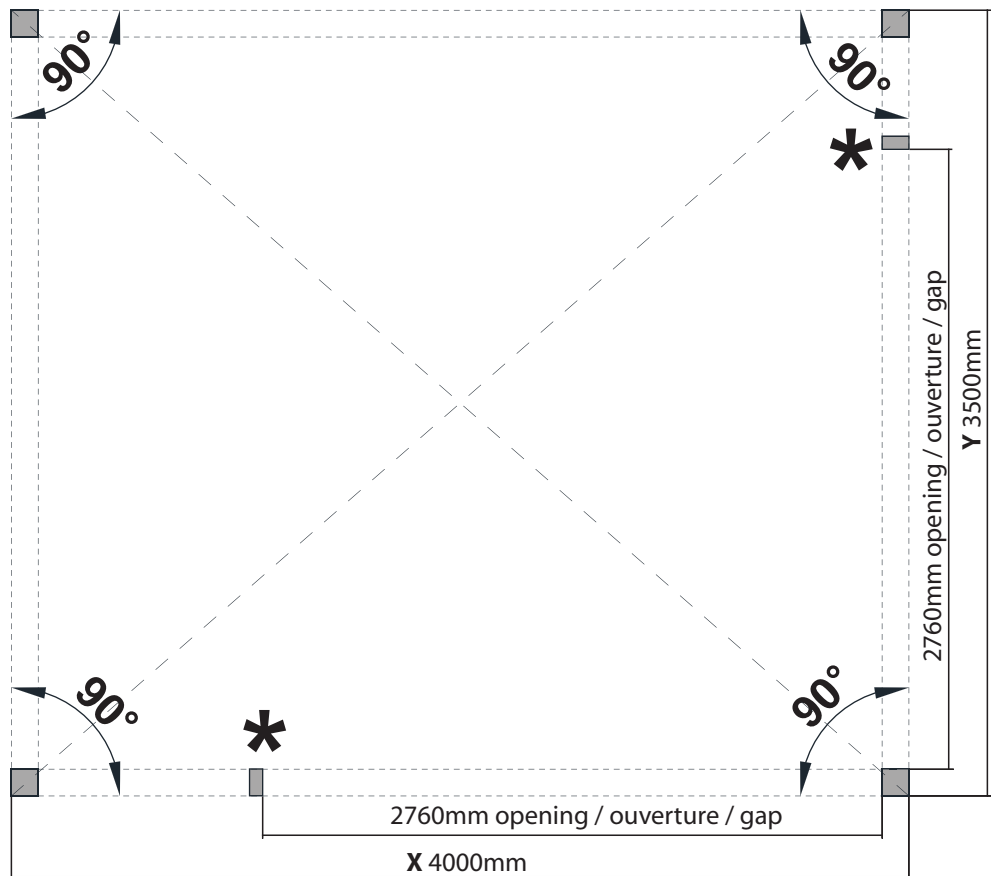
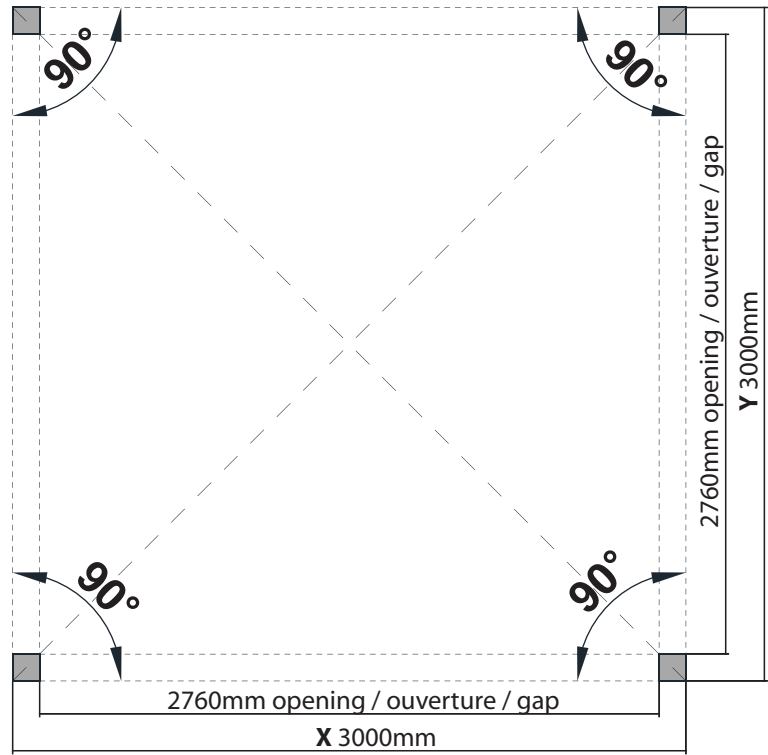

EXTERIOR	Y = 3000 mm	Y = 3500 mm	Y = 4000 mm
overmeten			
X = 3000 mm	3000 x 3000 mm	3000 x 3500 mm	3000 x 4000 mm
X = 3500 mm	3500 x 3000 mm	3500 x 3500 mm	3500 x 4000 mm
X = 4000 mm	4000 x 3000 mm	4000 x 3500 mm	4000 x 4000 mm

EXTERIOR met aanbouwmodule avec élément de série with extension module

VOORBEELD EXTERIOR AFMETINGEN
EXEMPLE EXTERIOR MESURES
EXAMPLE EXTERIOR MEASURES
 3000 x 3000 mm
 3500* x 3500* mm
 4000* x 4000* mm

VOORBEELD EXTERIOR AFMETINGEN
EXEMPLE EXTERIOR MESURES
EXAMPLE EXTERIOR MEASURES
 3500* x 3000 mm / 3000 x 3500* mm
 3500* x 4000* mm / 4000* x 3500* mm
 4000* x 3000 mm / 3000 x 4000* mm

* extra paal voor opening 2760mm bij schuifdeur

* extra poteau pour ouverture 2760mm pour porte coulissant

* extra post for gap 2760mm for sliding door

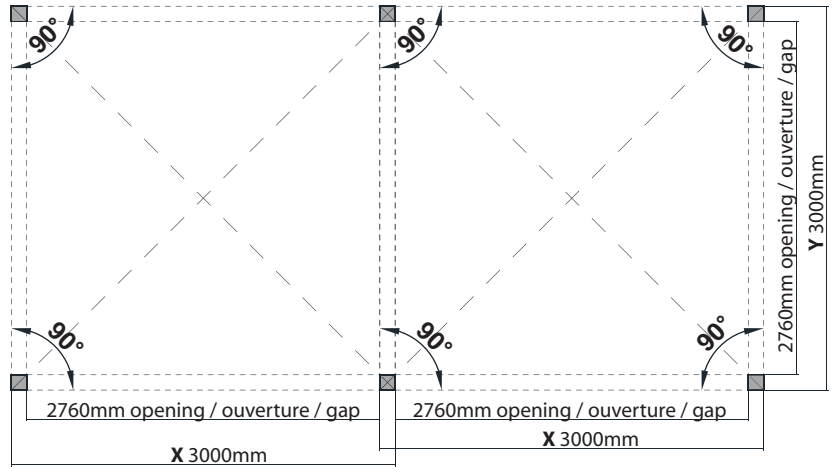

MEERDERE MODULES AANBOUWEN IS MOGELIJK!
IL EST POSSIBLE DE PLACER DES MODULES PLUS SUPPLEMENTAIRES!
IT'S POSSIBLE TO PLACE MORE EXTRA MODULES!

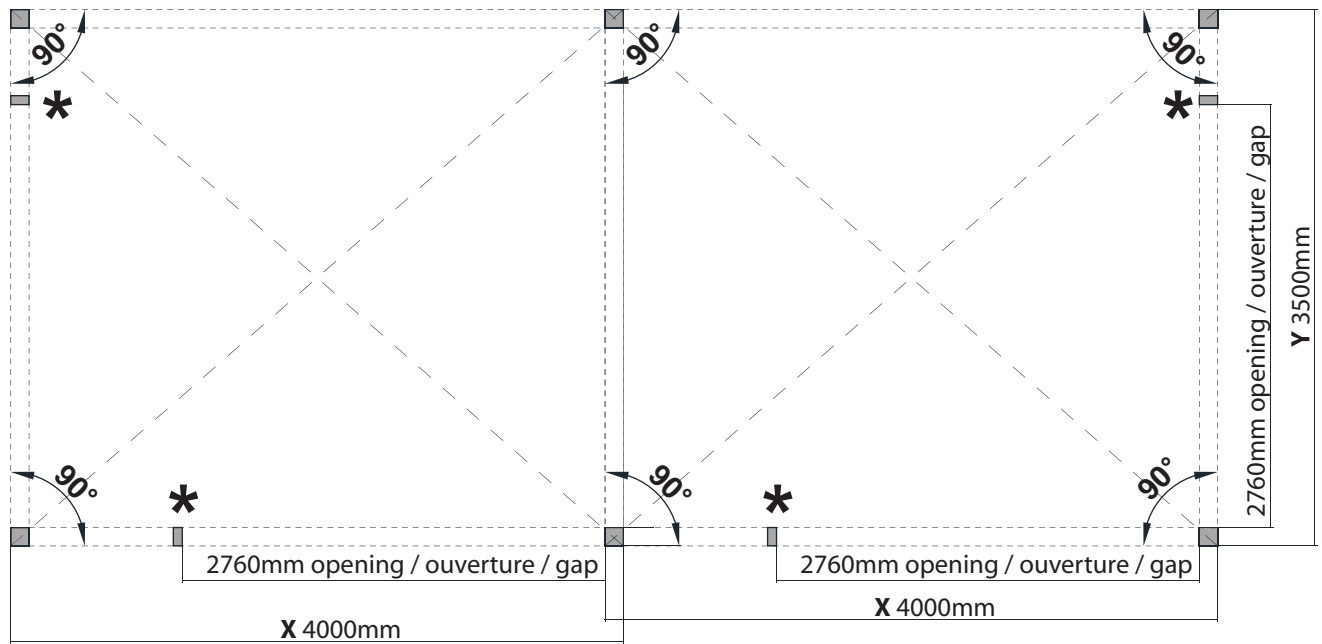

MEERDERE MODULES AANBOUWEN IS MOGELIJK!
IL EST POSSIBLE DE PLACER DES MODULES PLUS SUPPLEMENTAIRES!
IT'S POSSIBLE TO PLACE MORE EXTRA MODULES!



VANAF 2 MODULES= TOTAAL OVERMETEN MAAT PER MODULE -120mm
DE 2 MODULE= TAILLE TOTAL DE MESURE EN DEHORS -120mm
FROM 2 MODULES= TOTAL SIZE OF MEASUREMENT FOR EVERY MODULE -120mm

EXTERIOR	Y = 3000 mm	Y = 3500 mm	Y = 4000 mm
overmeten			
X = 3000 mm	3000 x 3000 mm	3000 x 3500 mm	3000 x 4000 mm
X = 3500 mm	3500 x 3000 mm	3500 x 3500 mm	3500 x 4000 mm
X = 4000 mm	4000 x 3000 mm	4000 x 3500 mm	4000 x 4000 mm

02 A

EXTERIOR

Positioneer de palen haaks, waterpas
Positionnez le poteaux droit, sur le même niveau

PU-LIJM / COLLE PU / PU GLUE

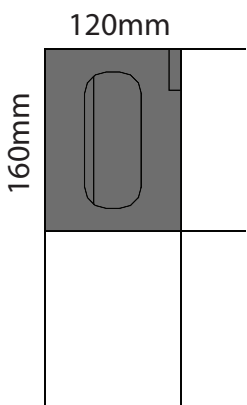
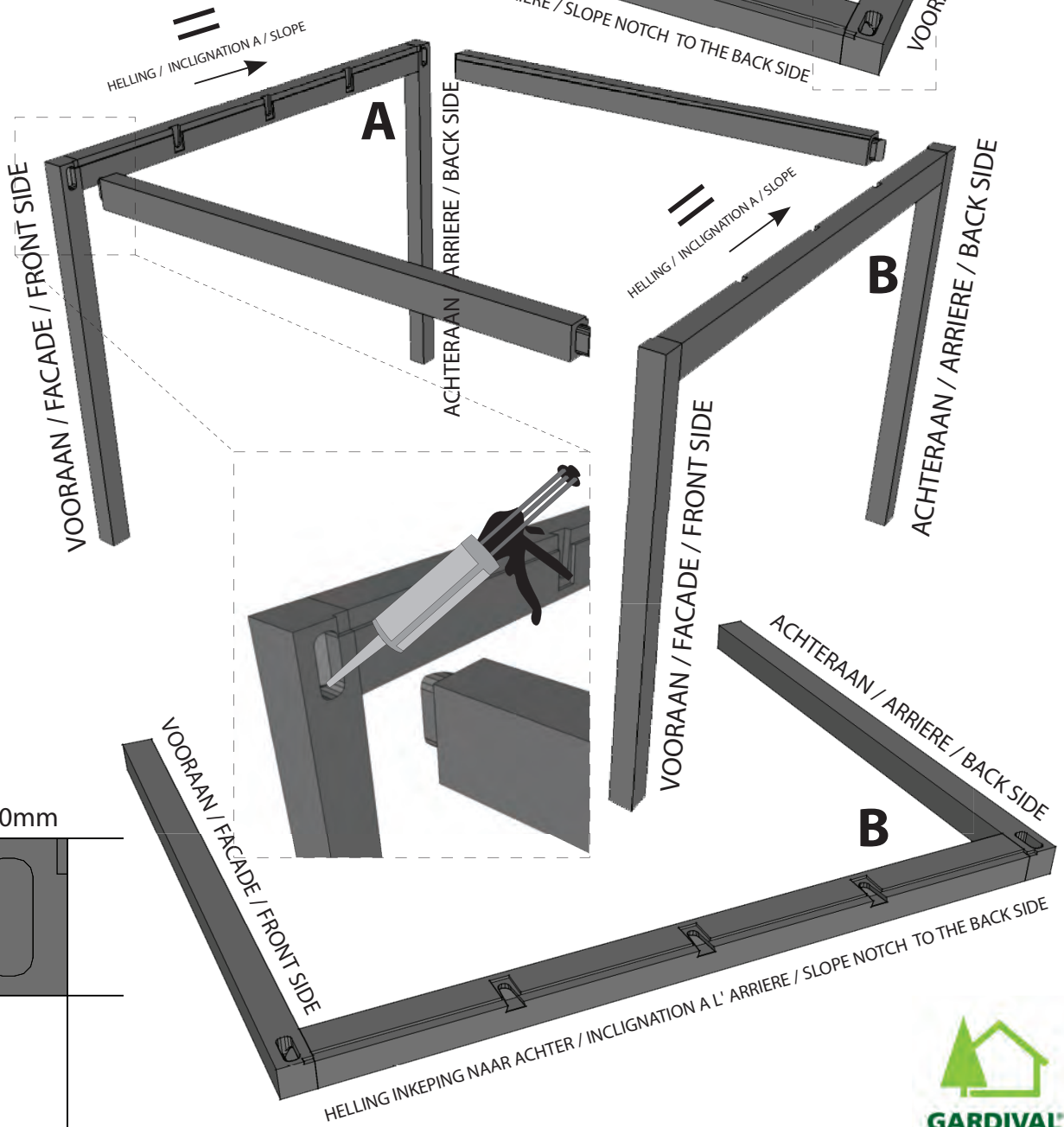
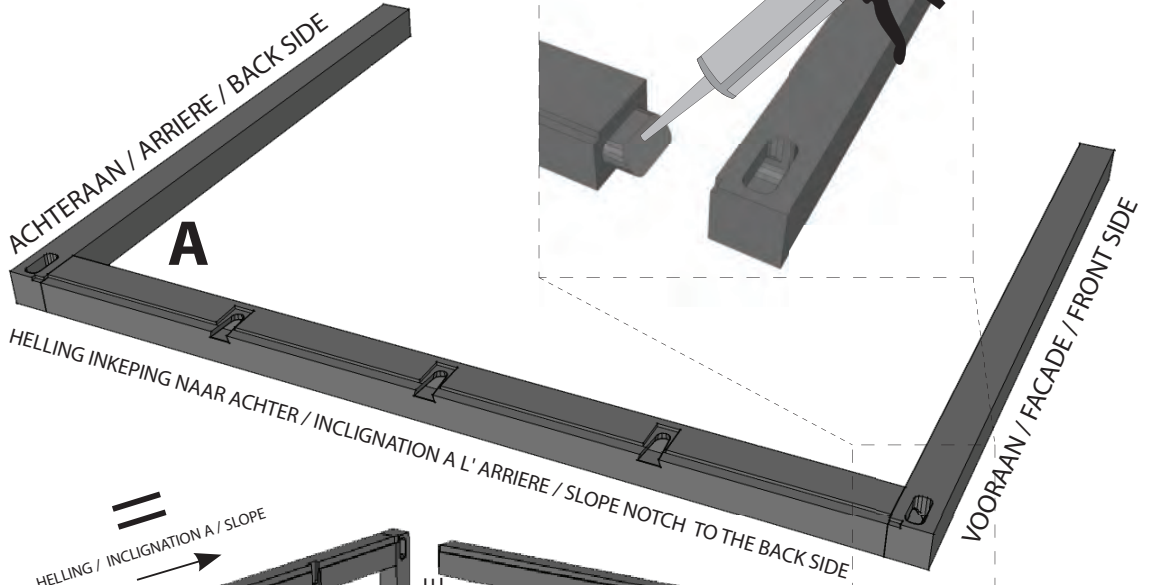

EXTERIOR met aanbouwmodule avec élément de série with extension module

Positioneer de palen haaks, waterpas
Positionnez le poteaux droit, sur le même niveau

PU-LIJM / COLLE PU / PU GLUE

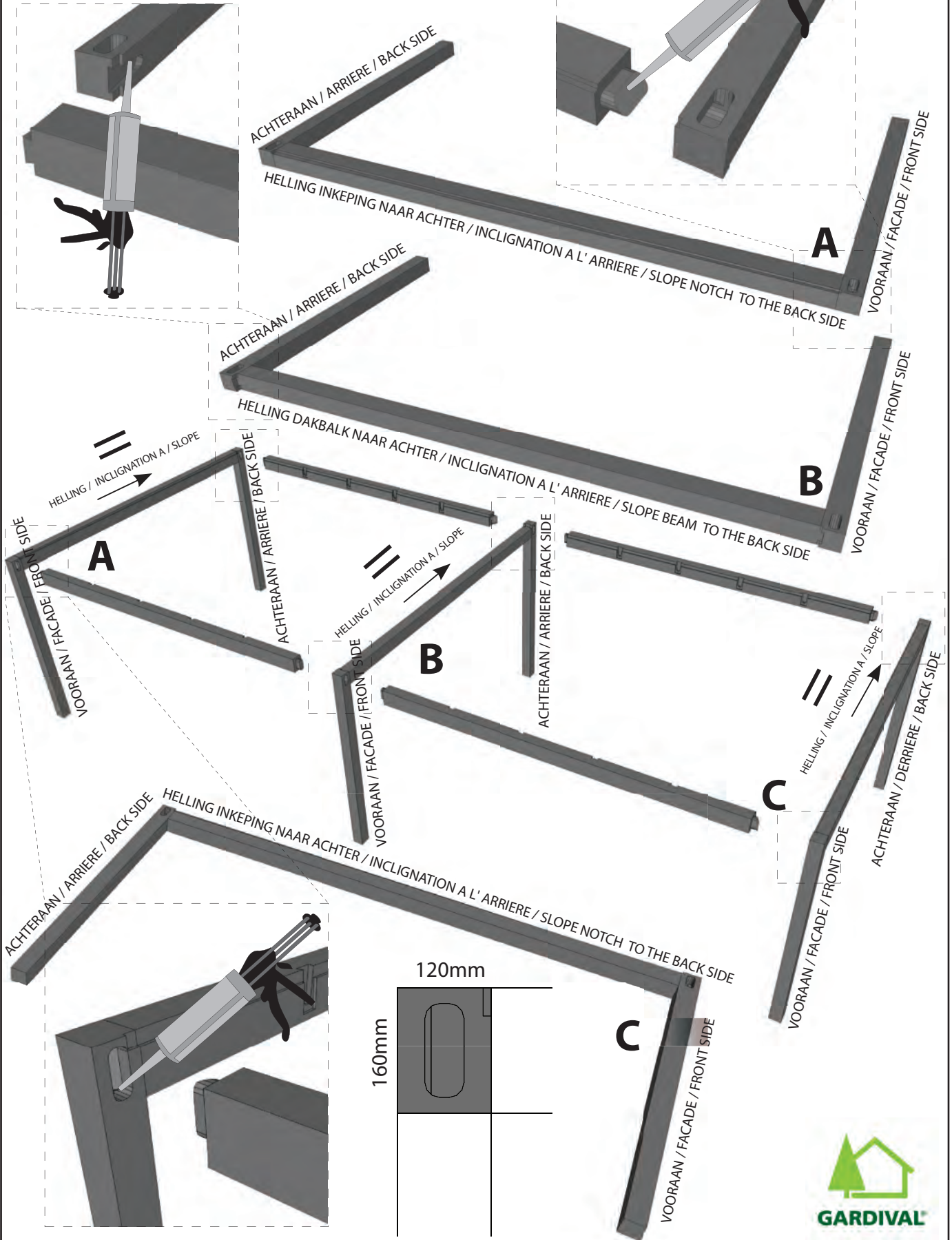

03 A

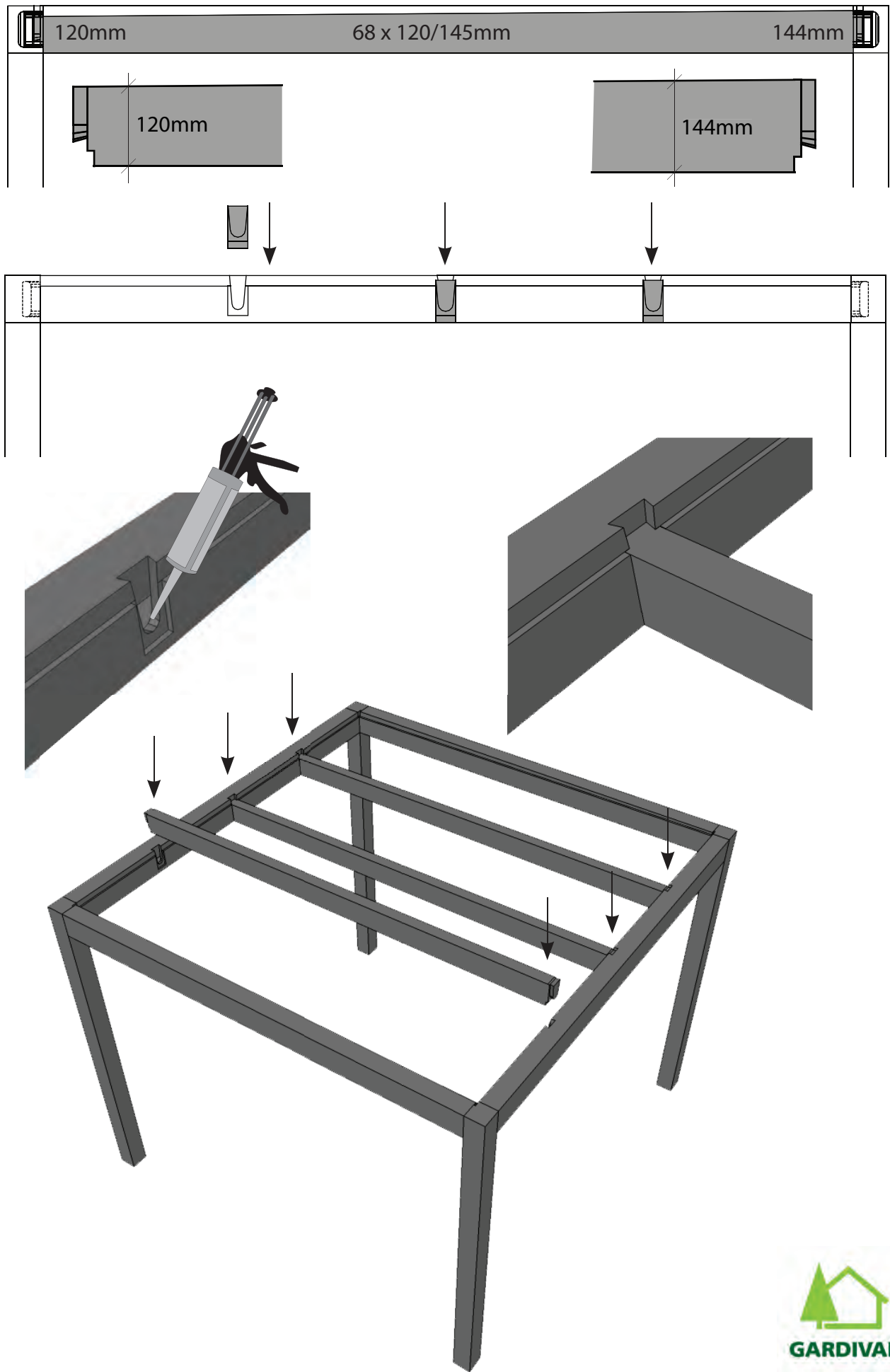

03 B

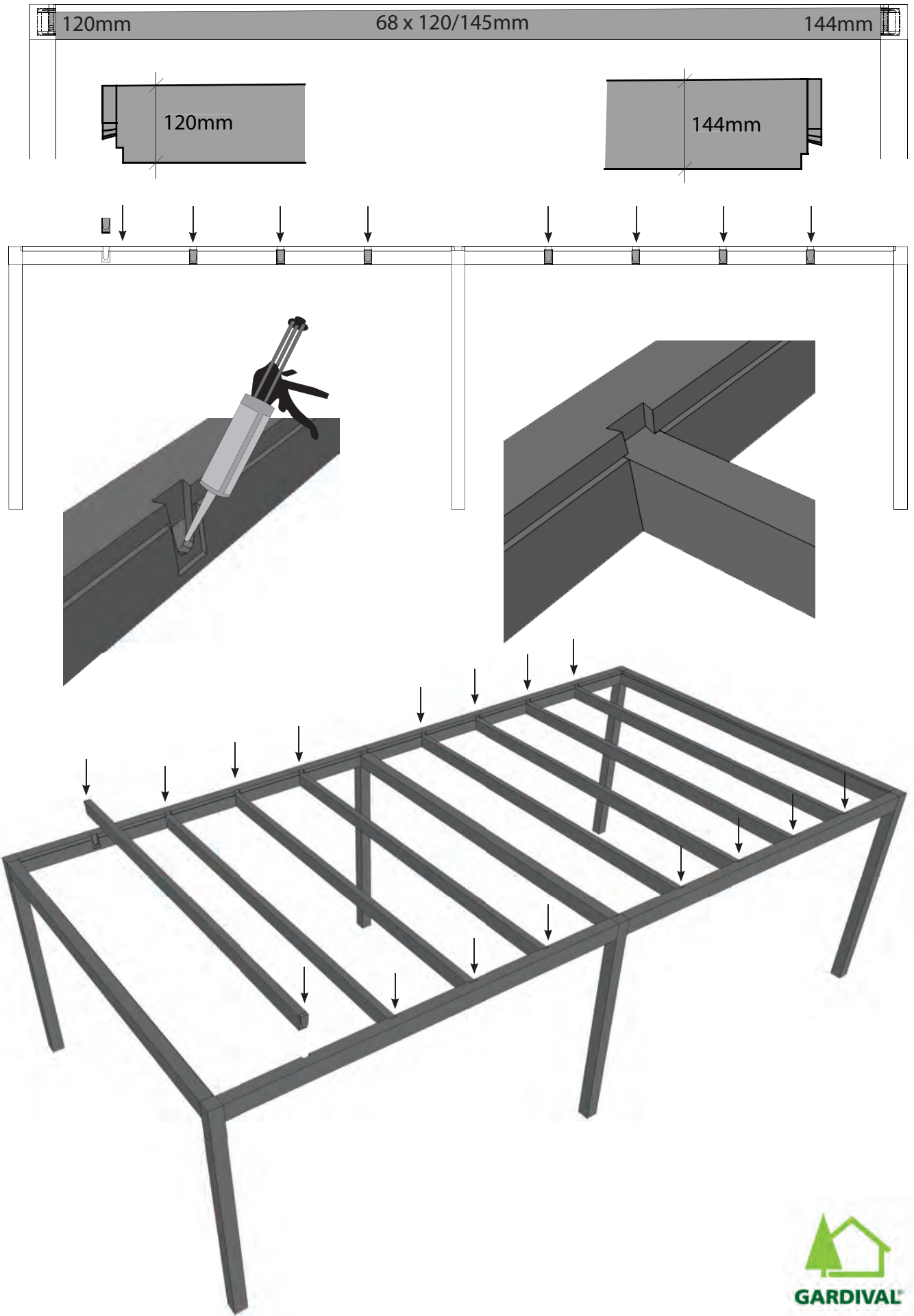

04 A

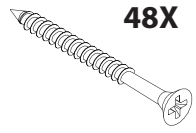

Ø 5 x 50mm

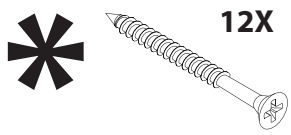
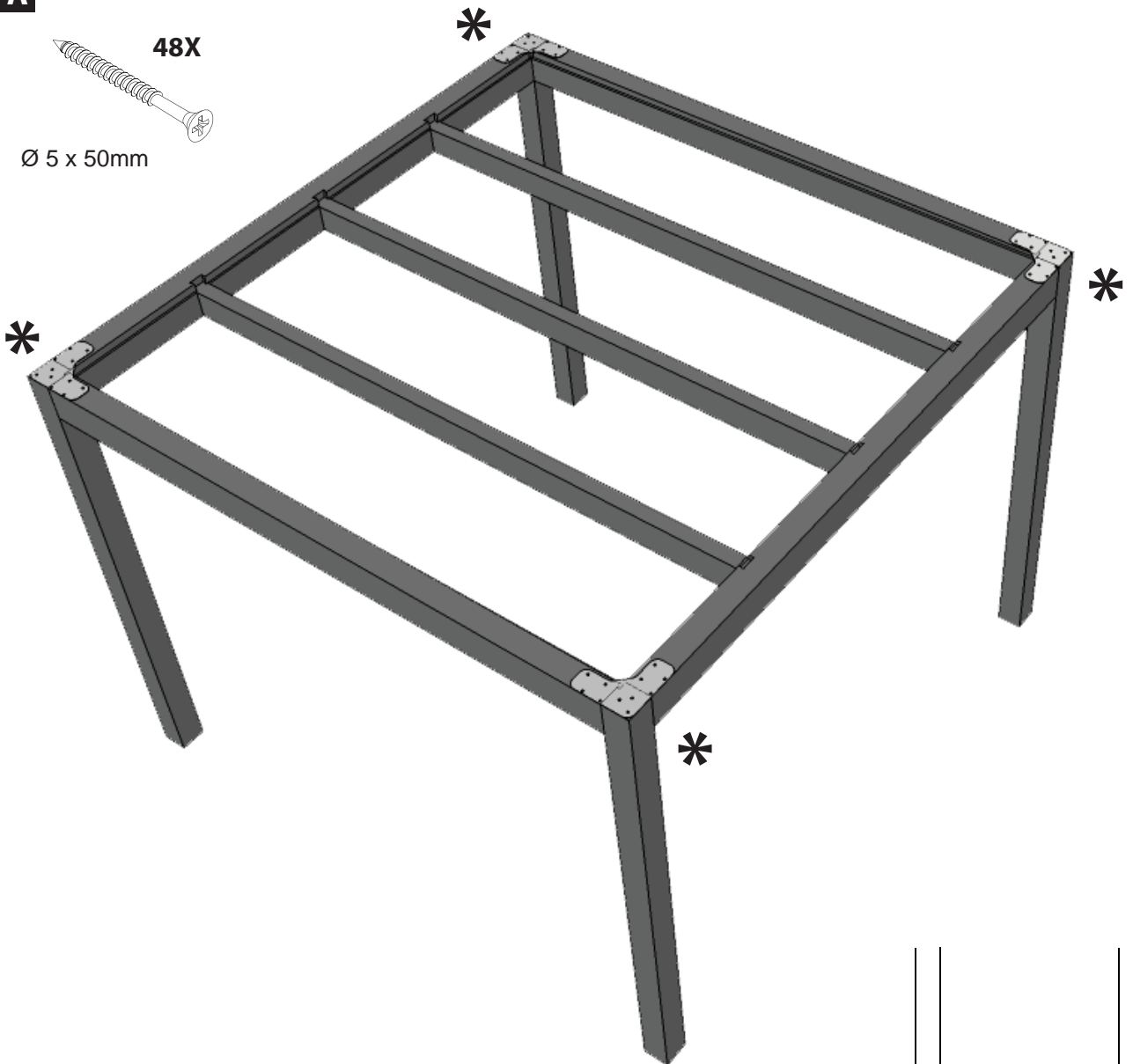

Ø 5 x 50mm

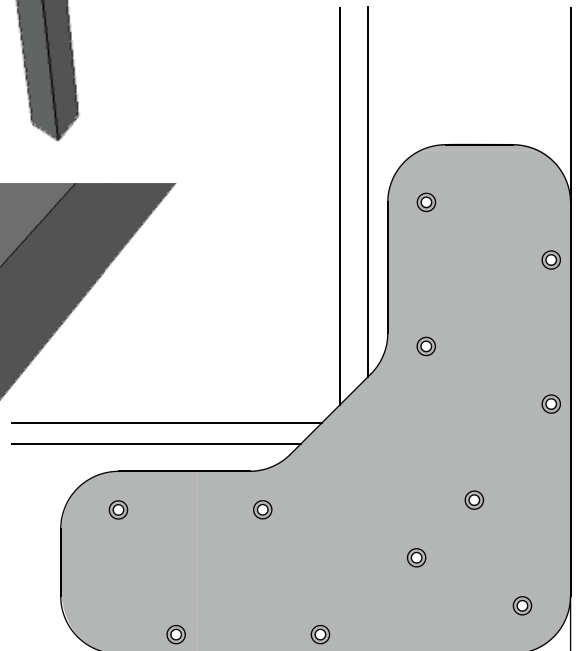
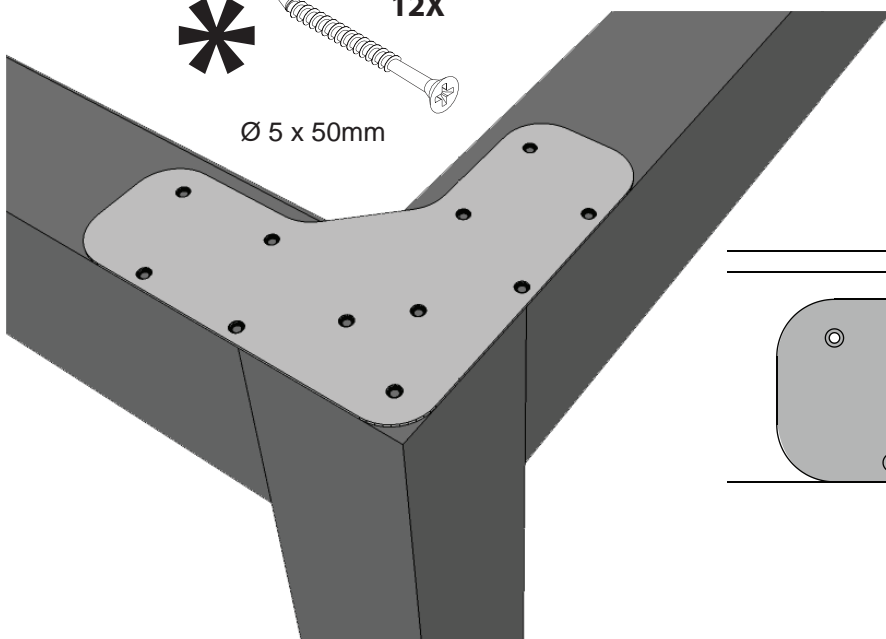

04 B

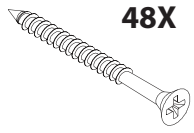

Ø 5 x 50mm

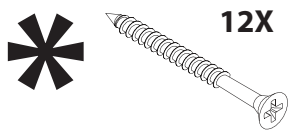
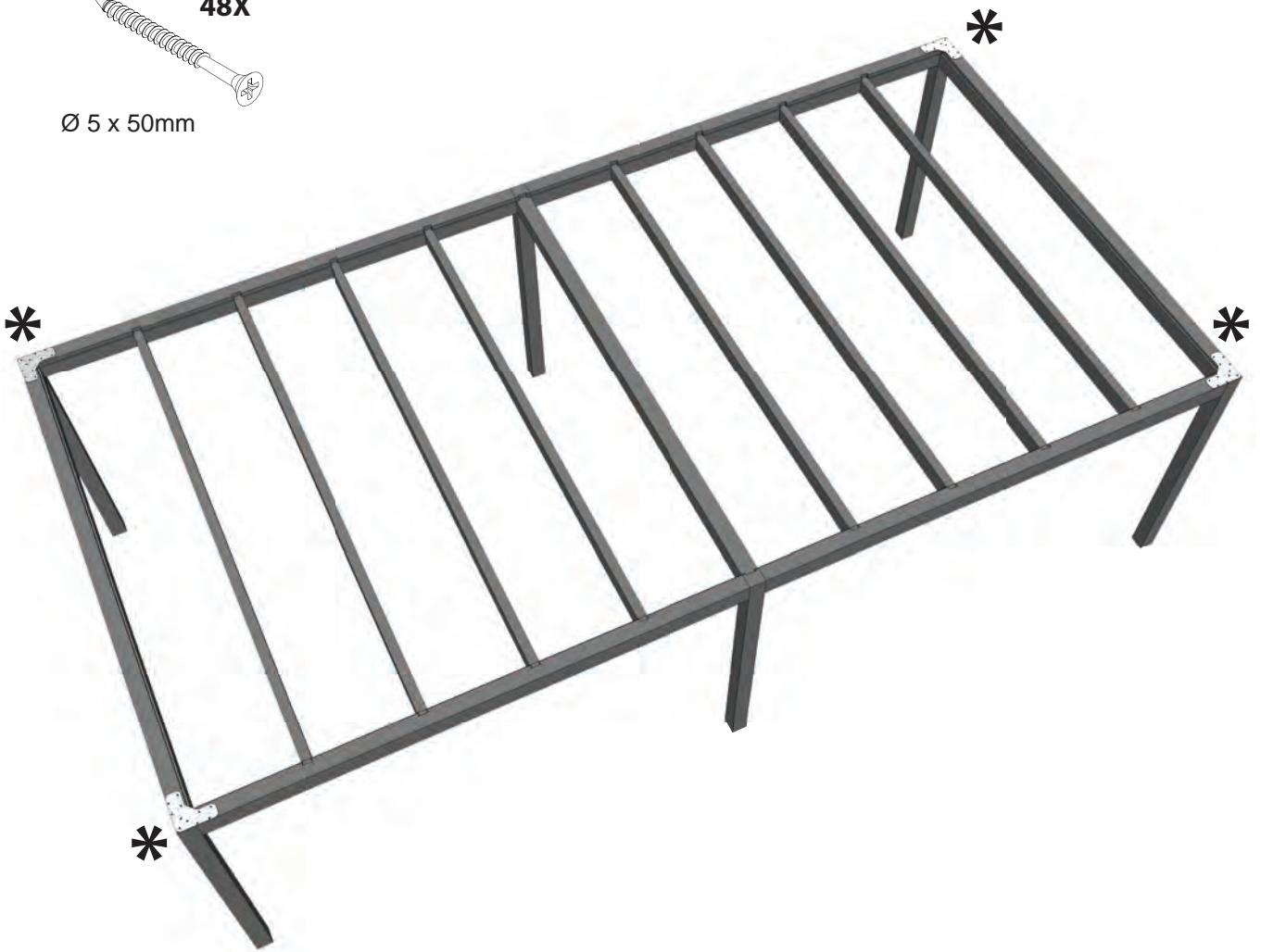

Ø 5 x 50mm

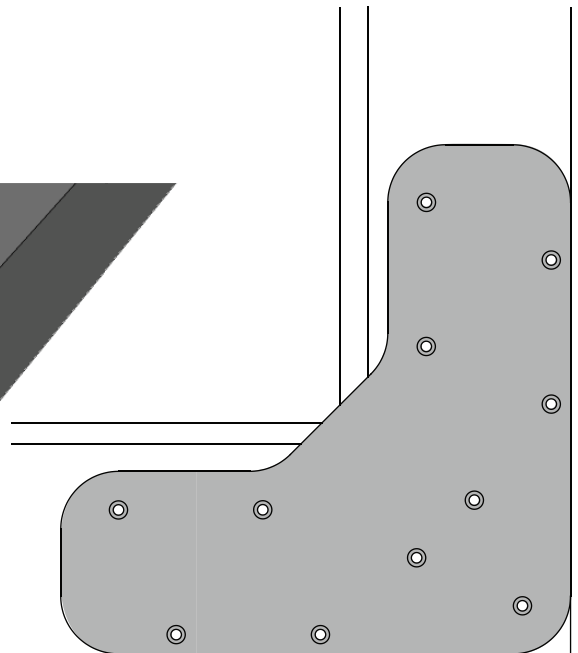
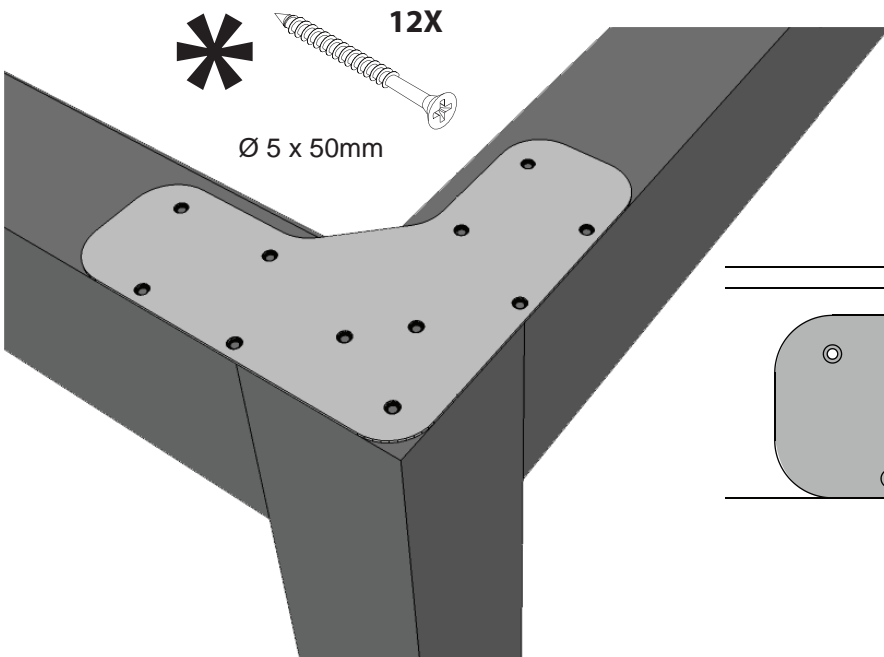

05

Volle wand / Paroi pleine / Full wall

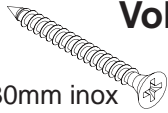

Ø 4 x 30mm inox

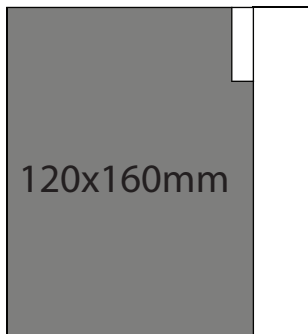
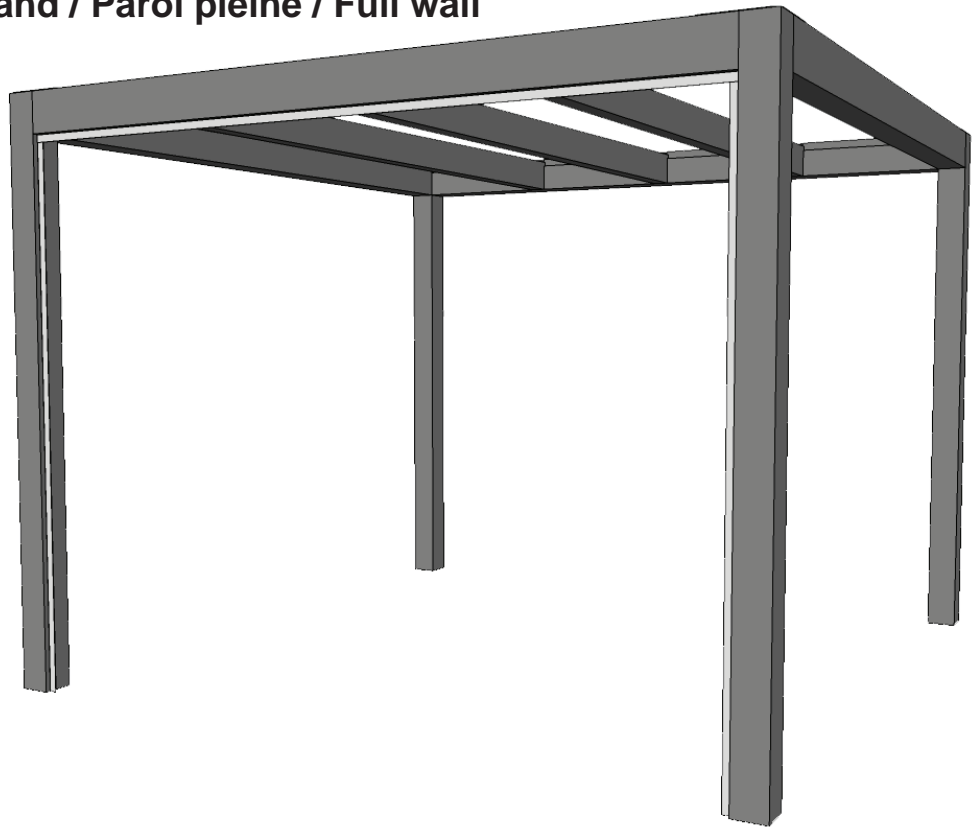

120x160mm

buiten / extérieur / outside

20mm

binnen / intérieur / inside

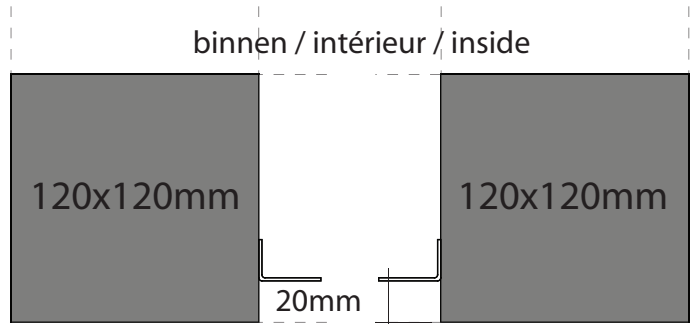

binnen / intérieur / inside

120x120mm

120x120mm

20mm

buiten / extérieur / outside

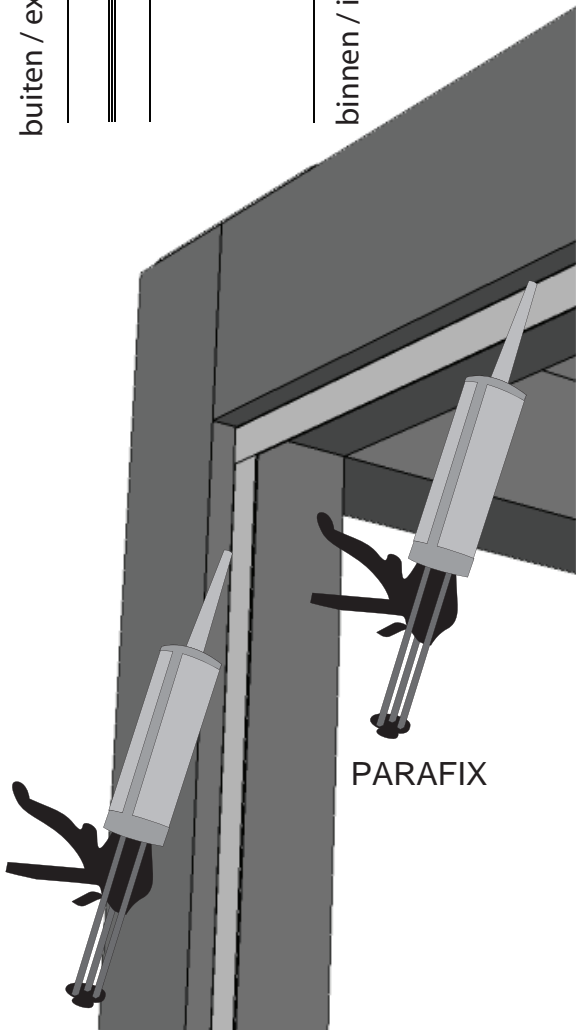

PARAFIX

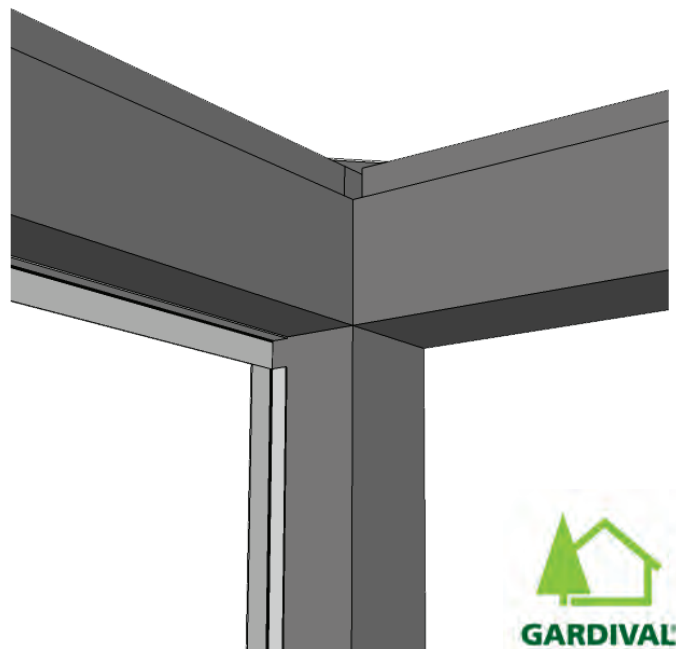

06

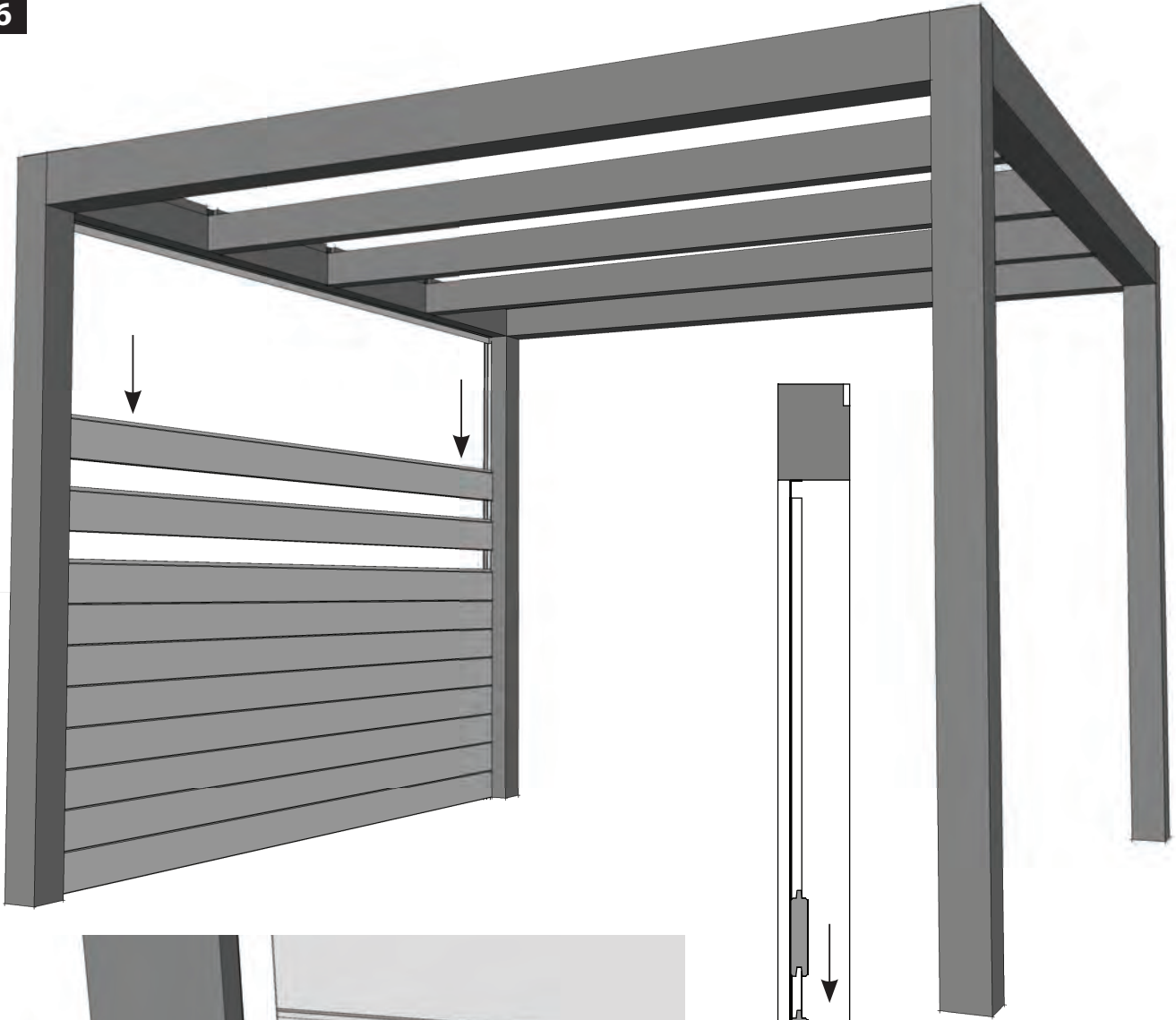

buiten / extérieur / outside

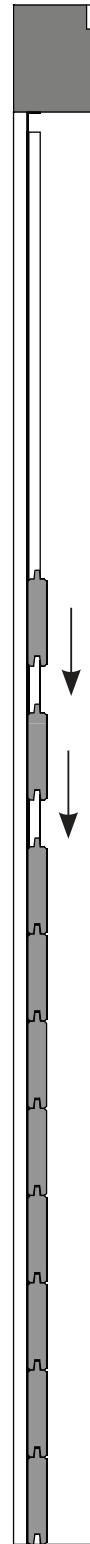

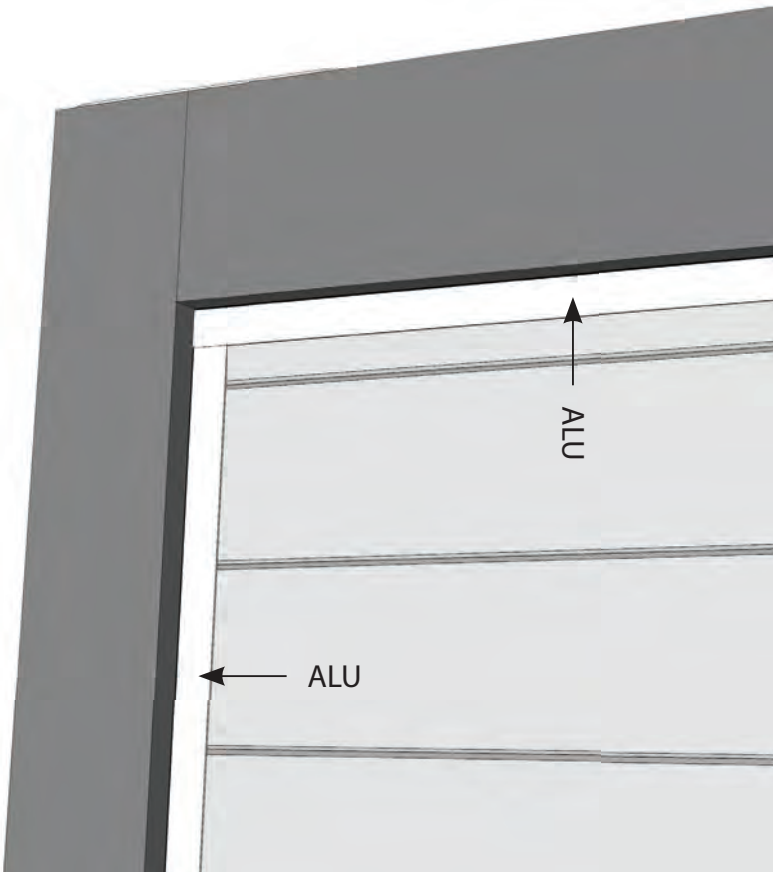
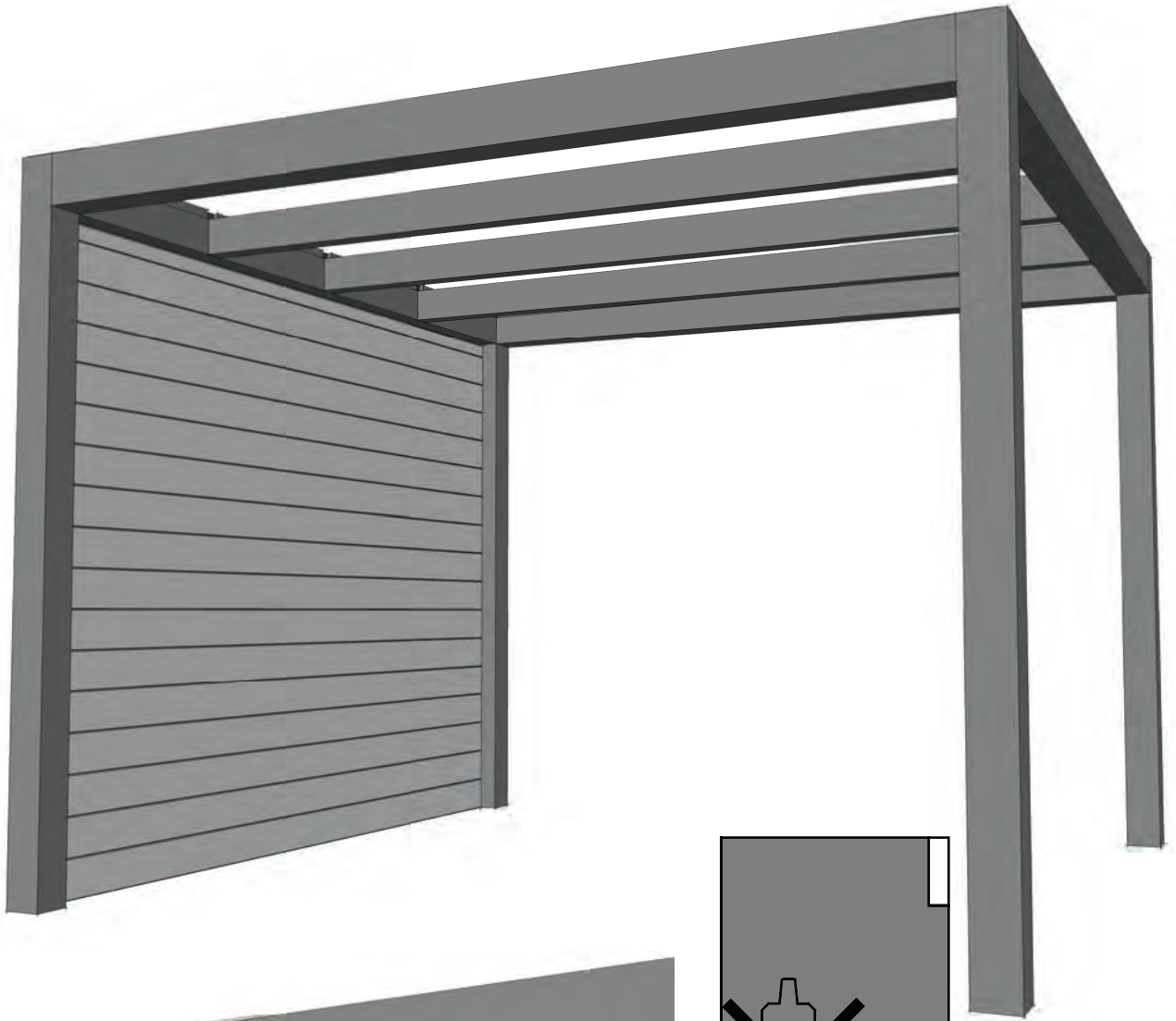

buiten / extérieur / outside

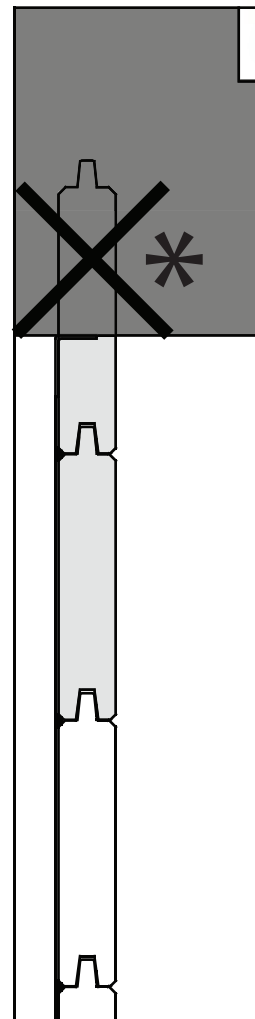

- * afzagen
- * couper
- * saw away



08

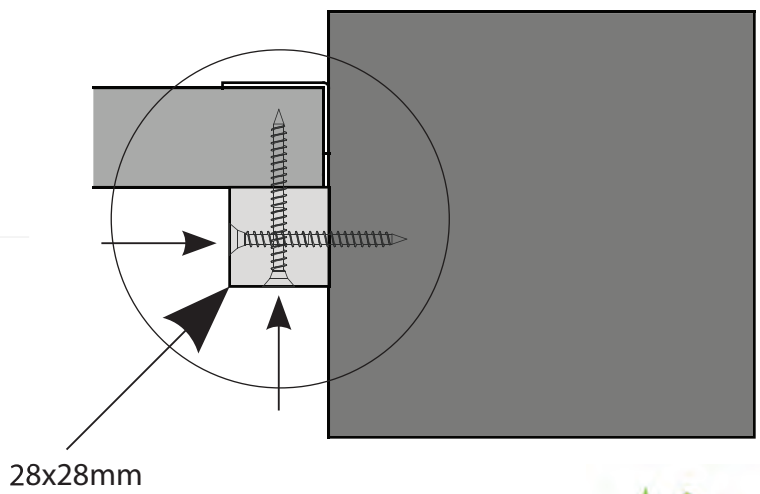
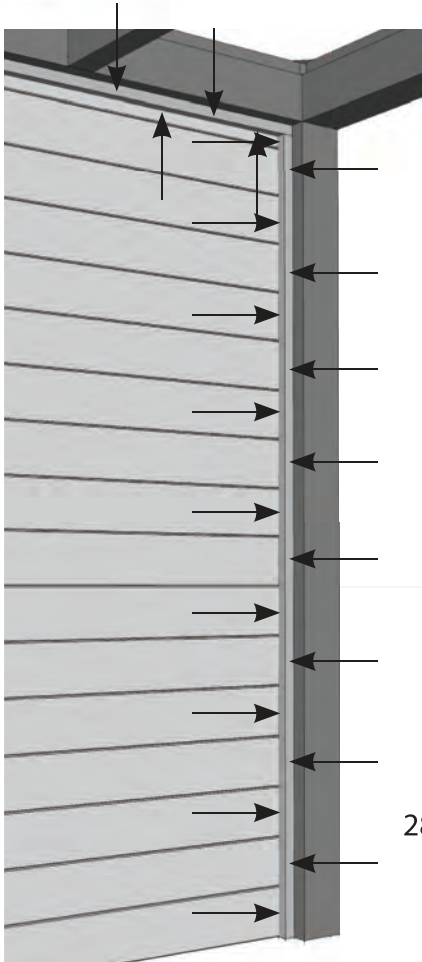
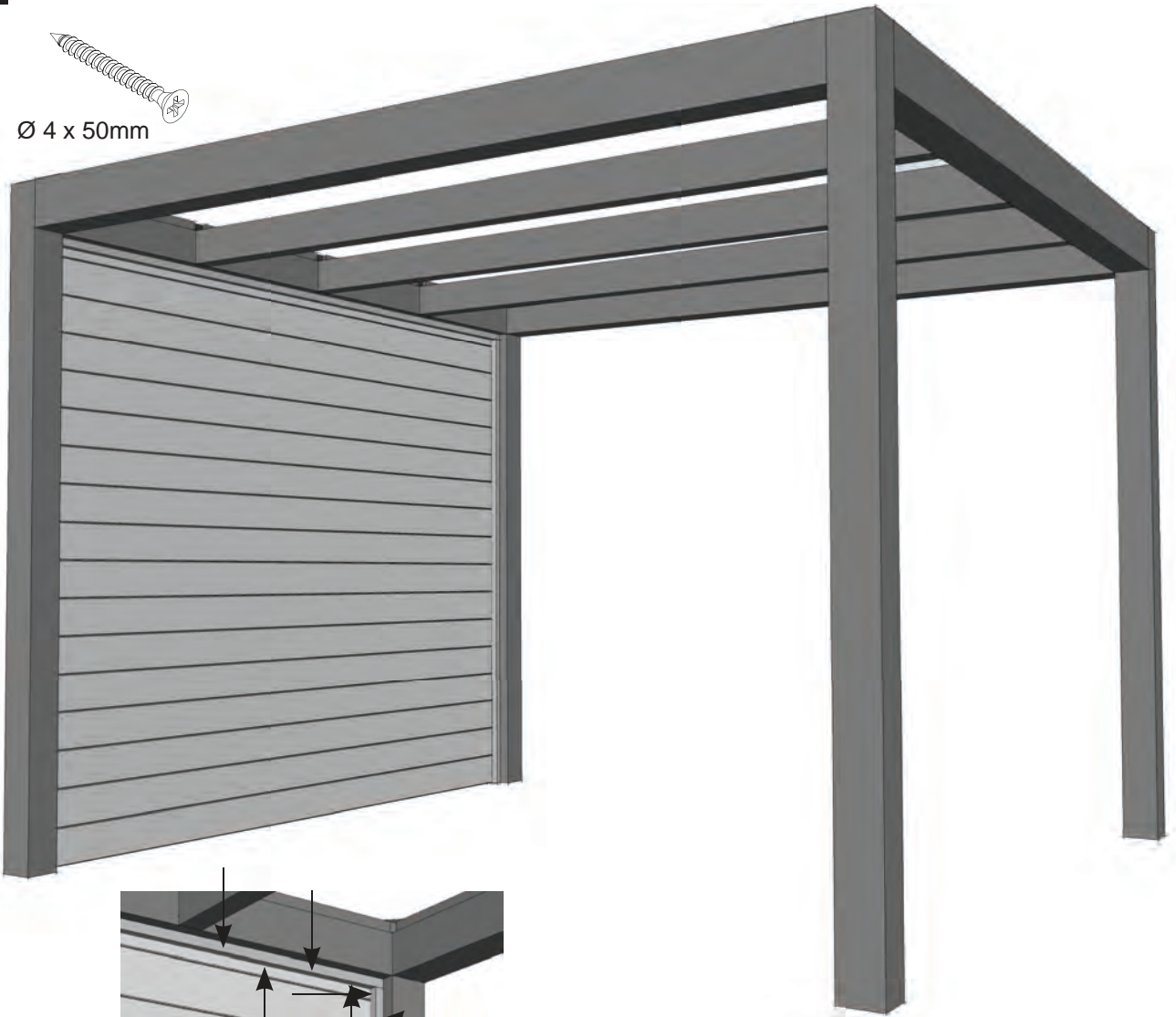
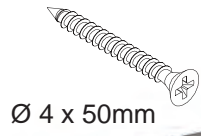

09

Wand met vast raam / Paroi et fenetre fixe / Wall with fixed window



Ø 4 x 50mm

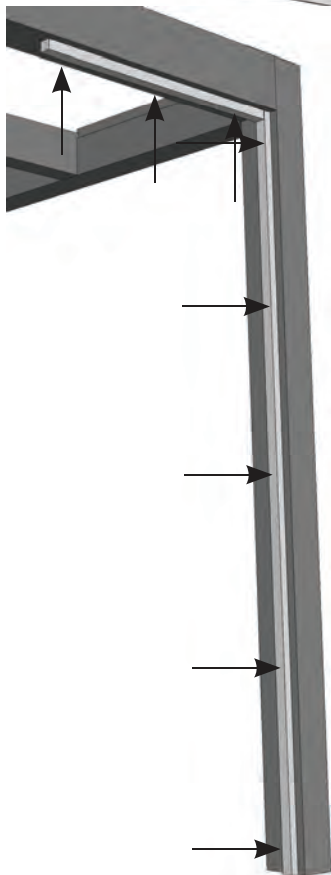
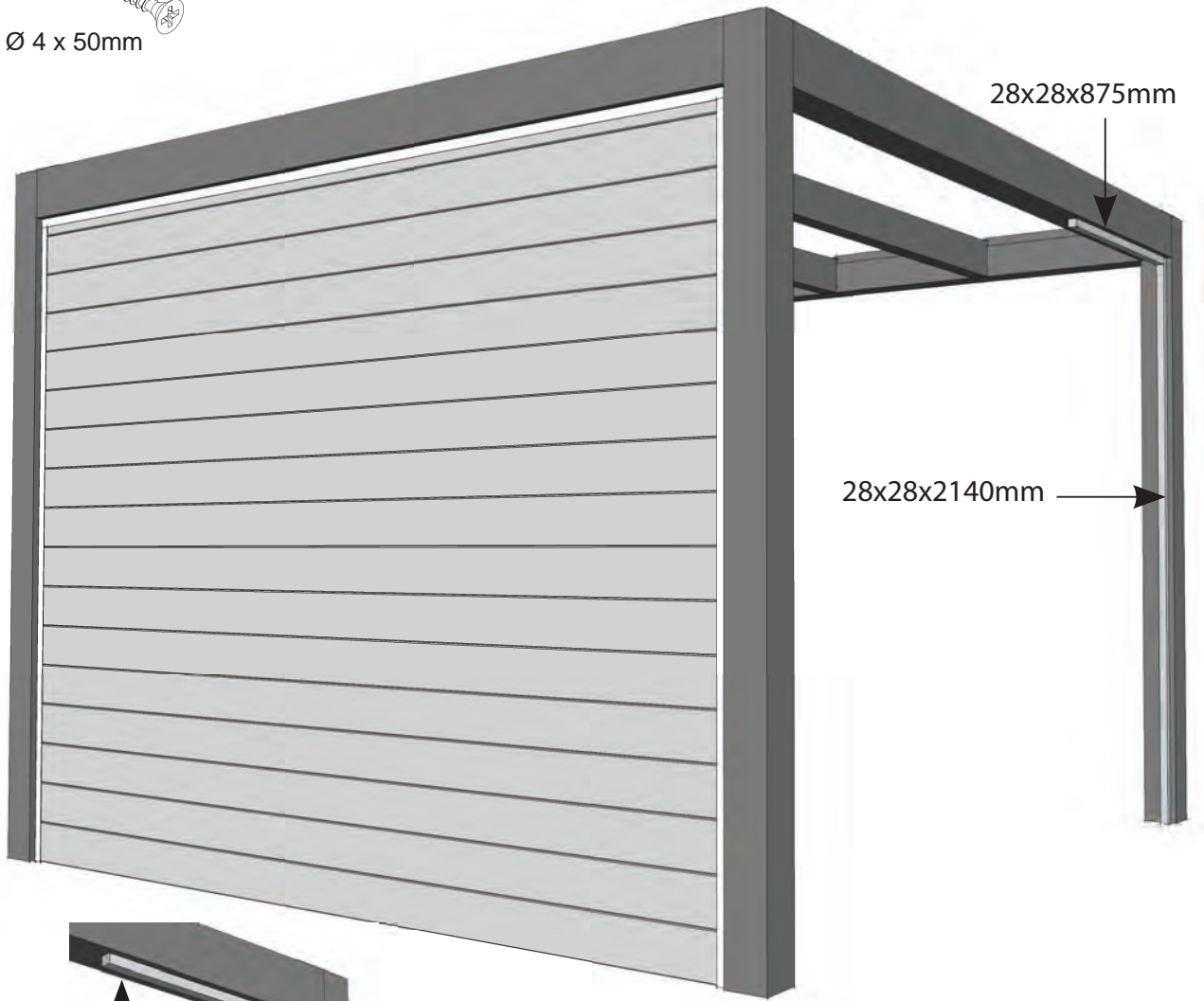

binnen / intérieur / inside

28x28mm

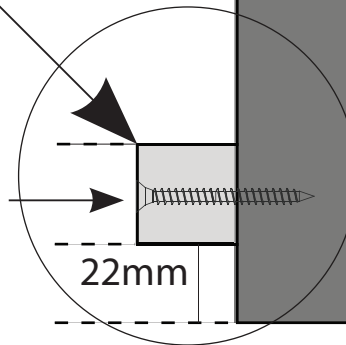

22mm

buiten / extérieur / outside



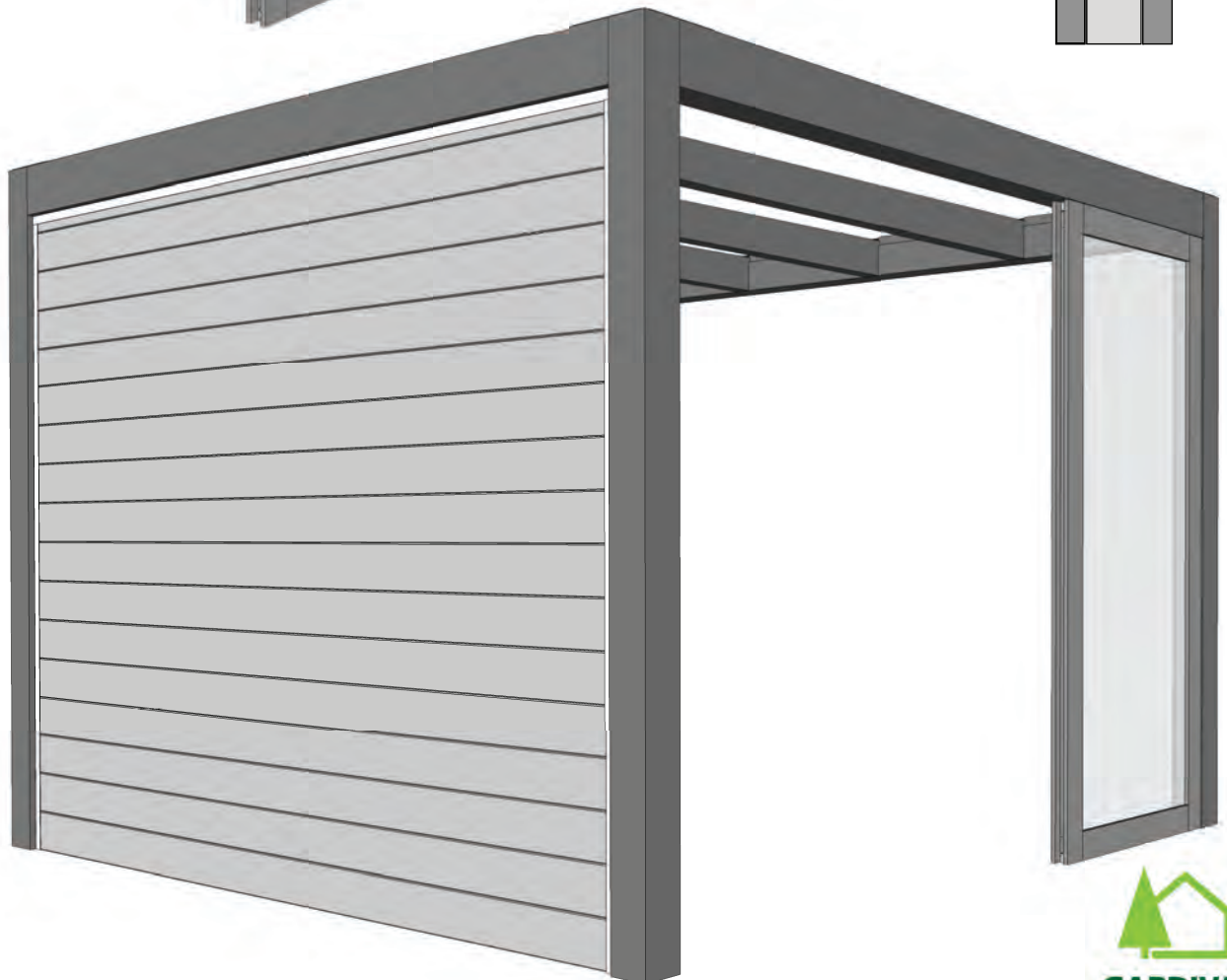
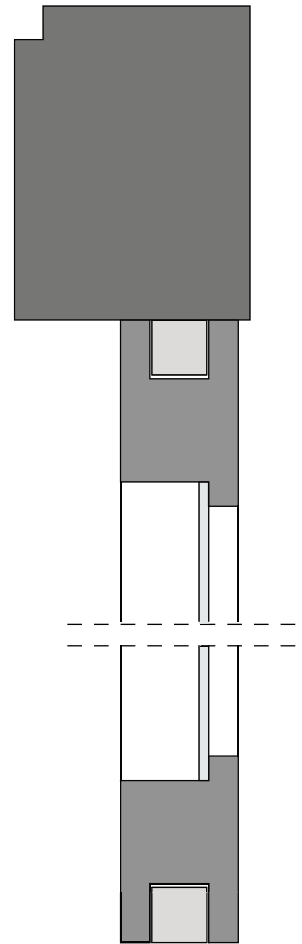
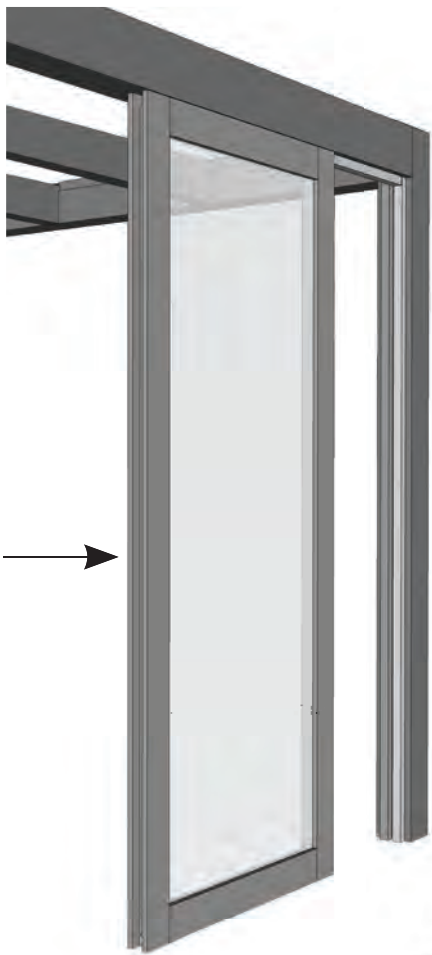

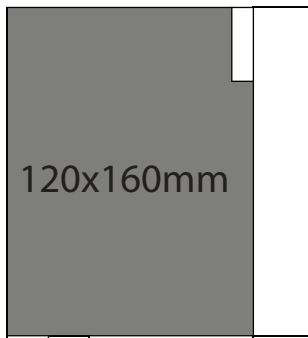

buiten / extérieur / outside

20mm

binnen / intérieur / inside

binnen / intérieur / inside

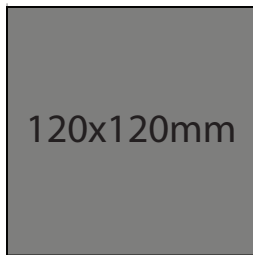

20mm

buiten / extérieur / outside

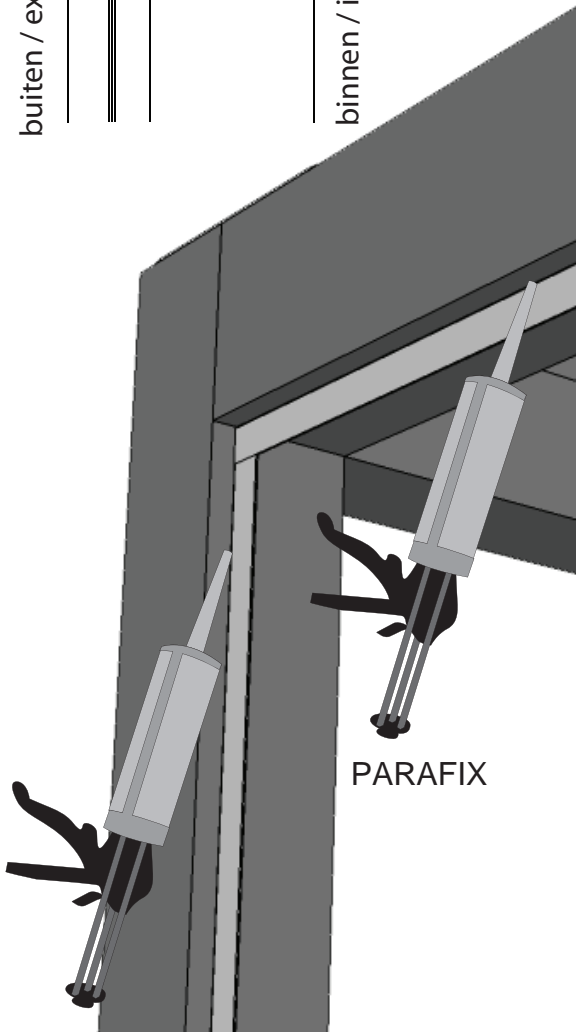

PARAFIX

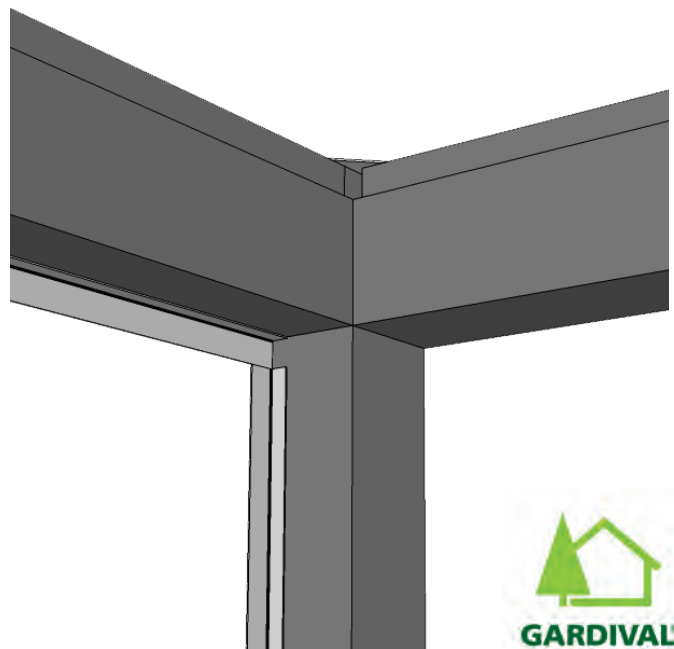



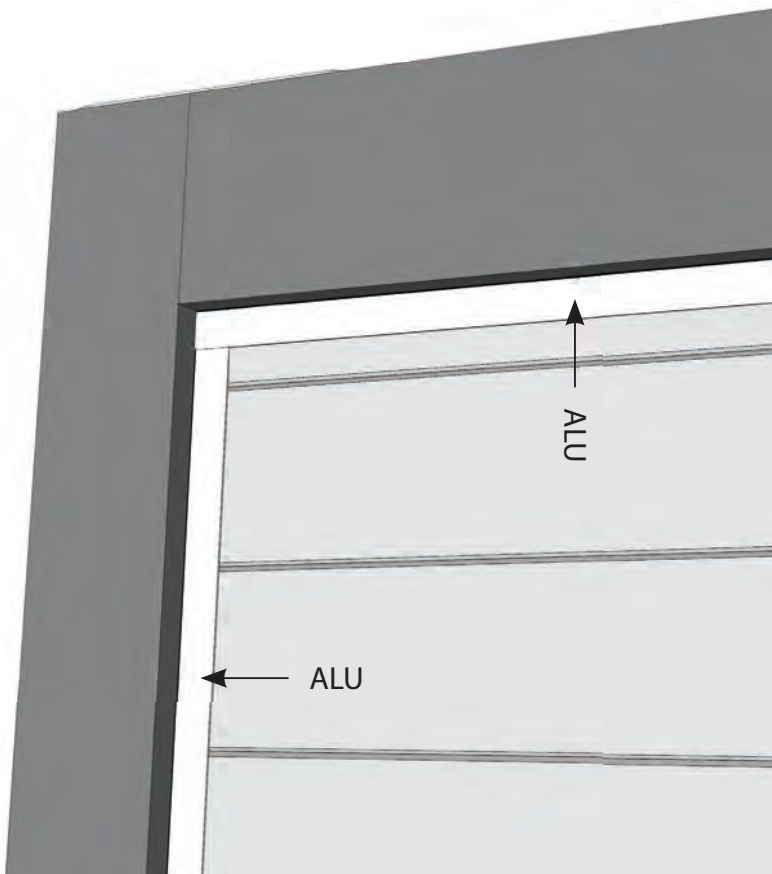
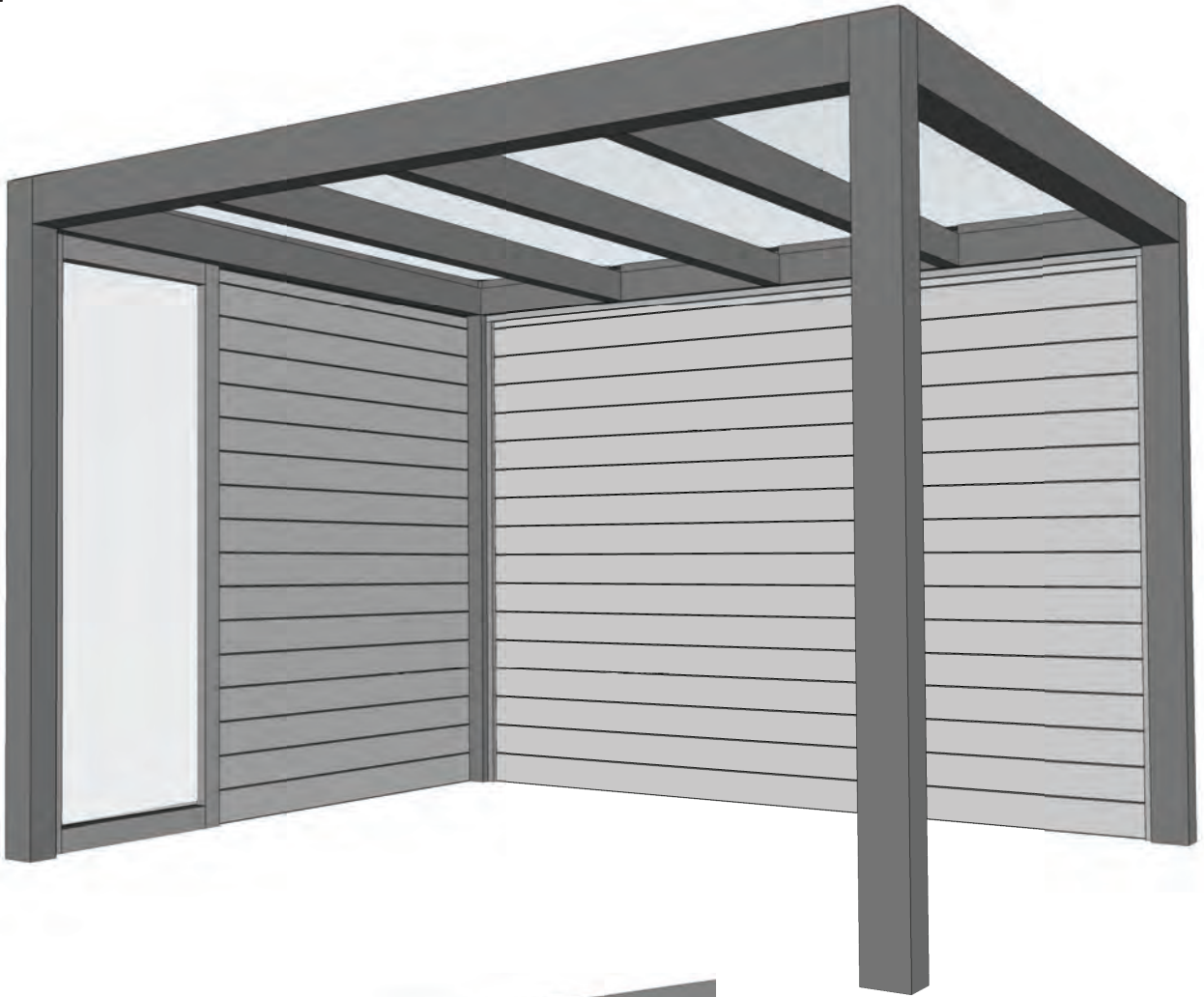

buiten / extérieur / outside

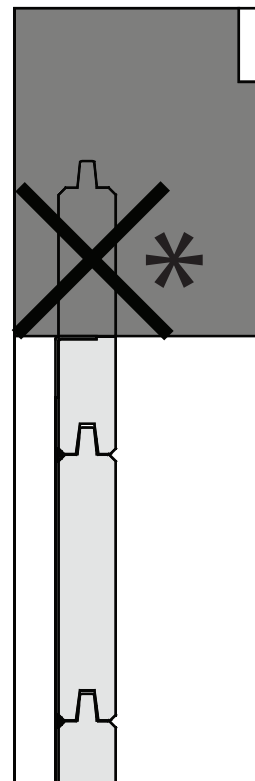

- * afzagen
- * couper
- * saw away





Ø 4 x 50mm

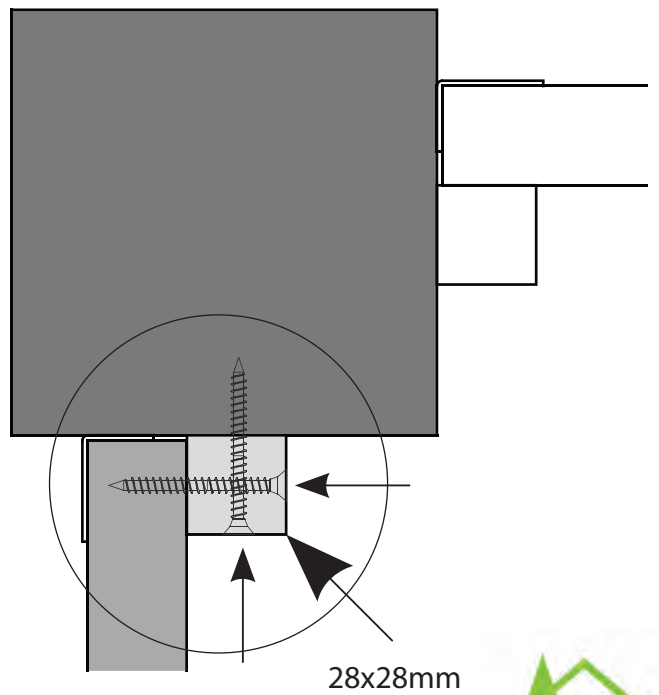
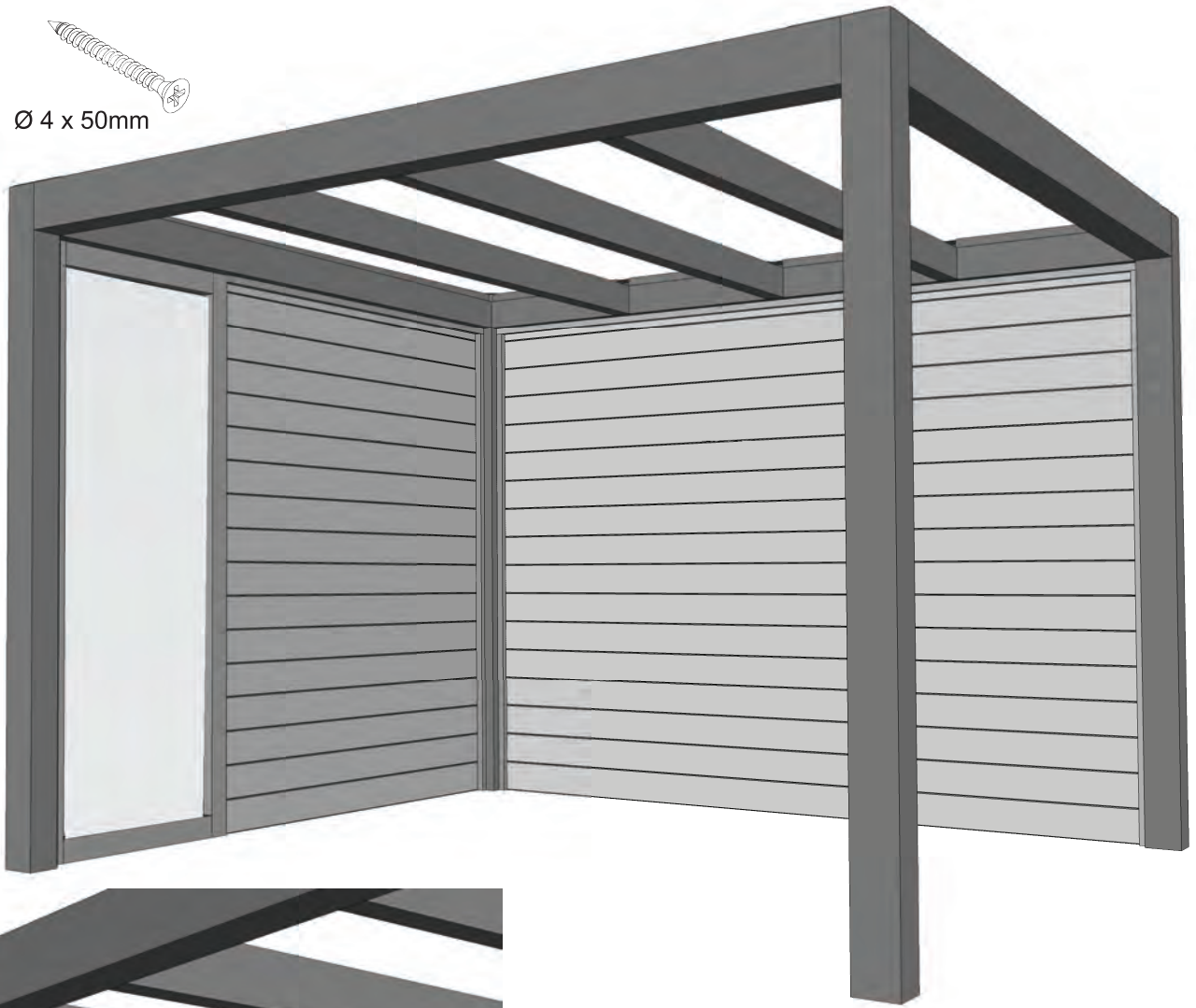



Ø 4 x 50mm

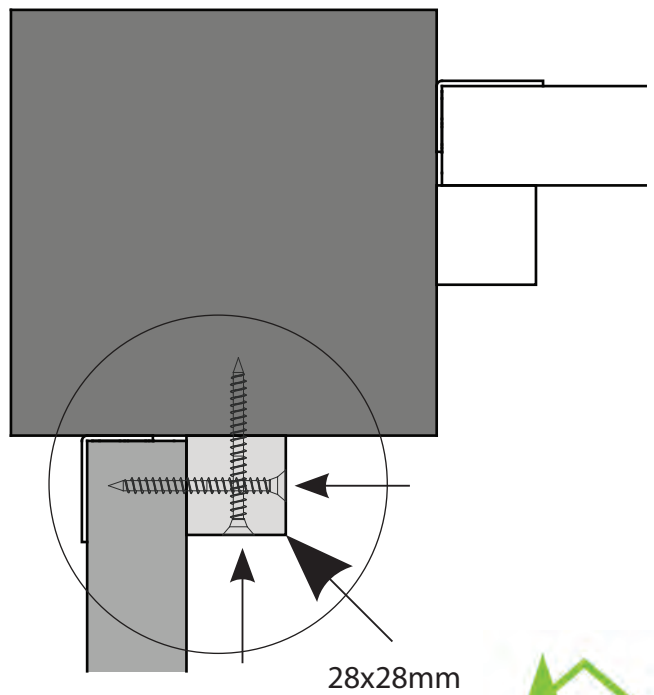
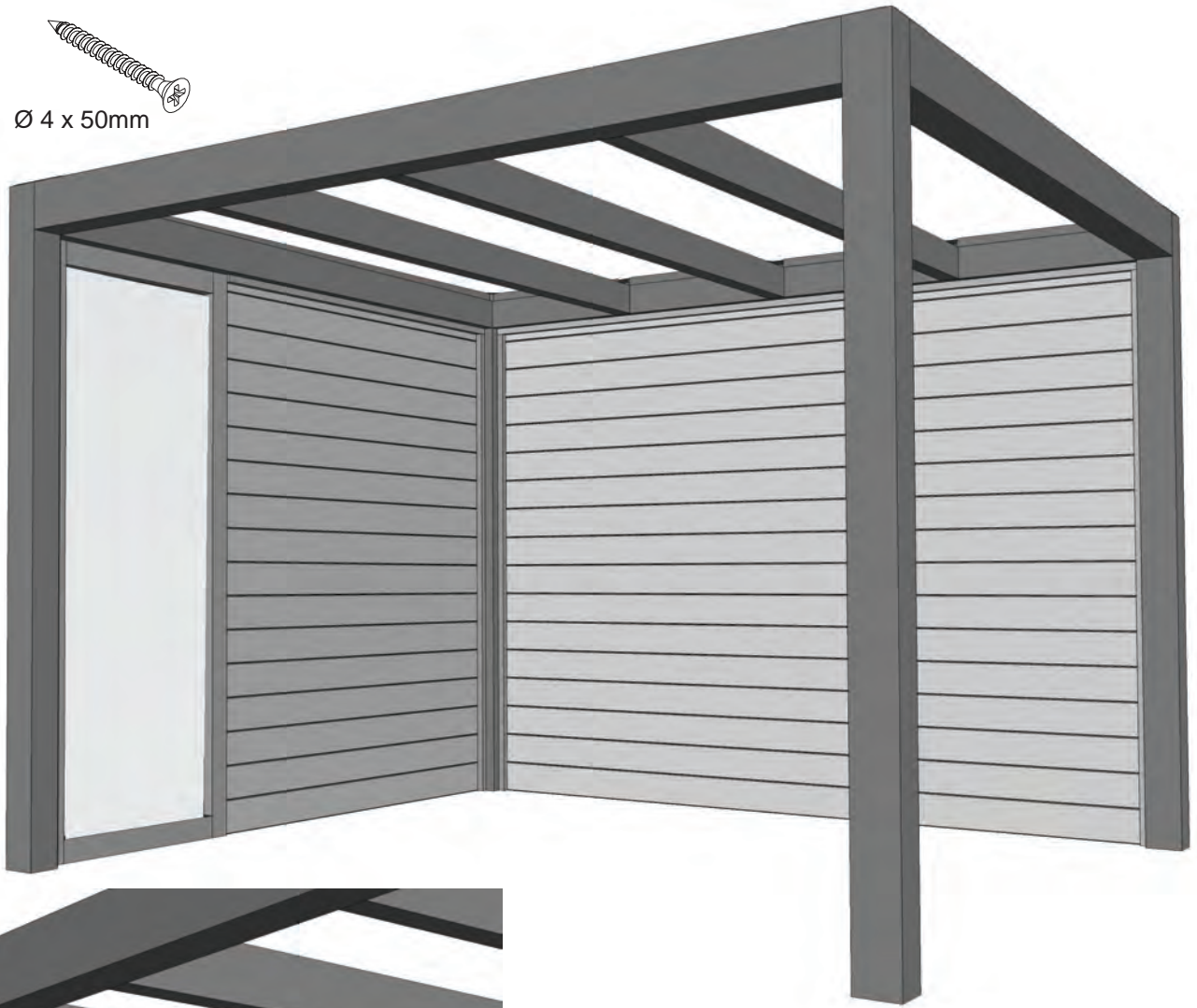

28x28mm



Ø 4 x 30mm INOX

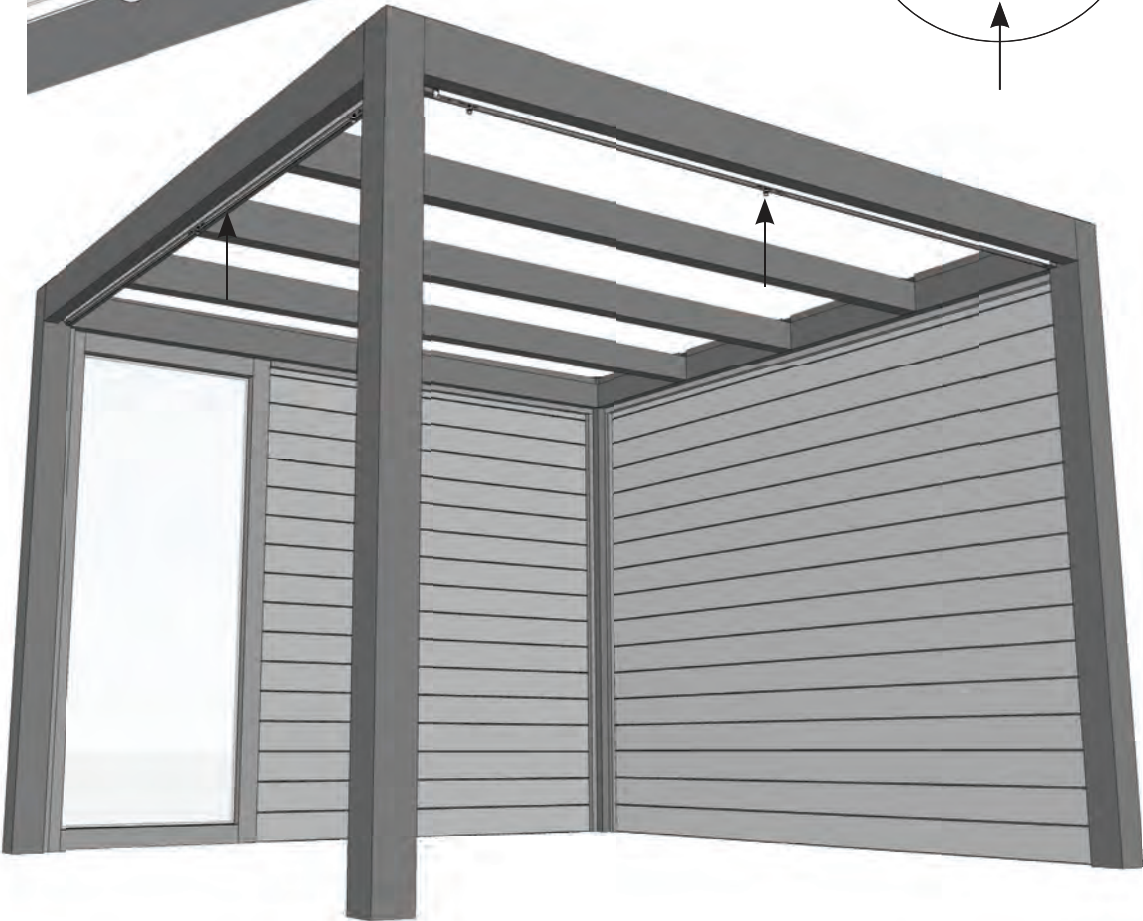
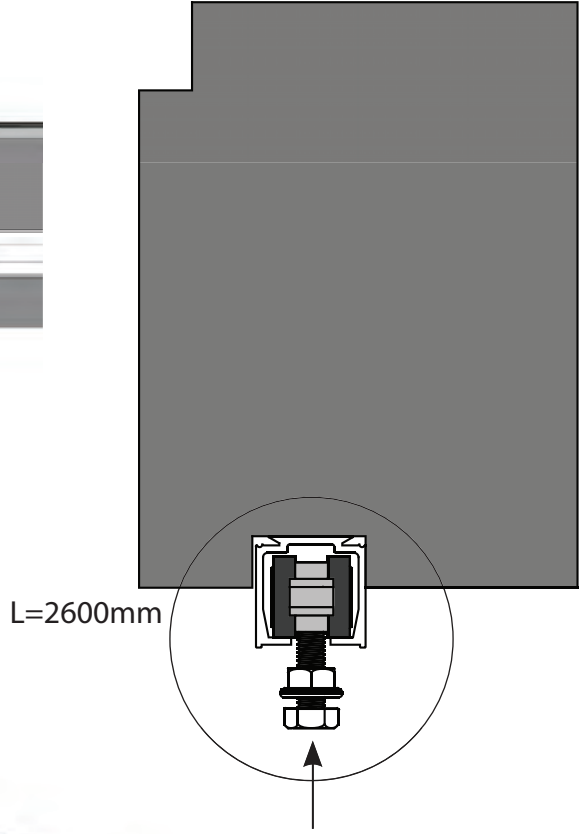
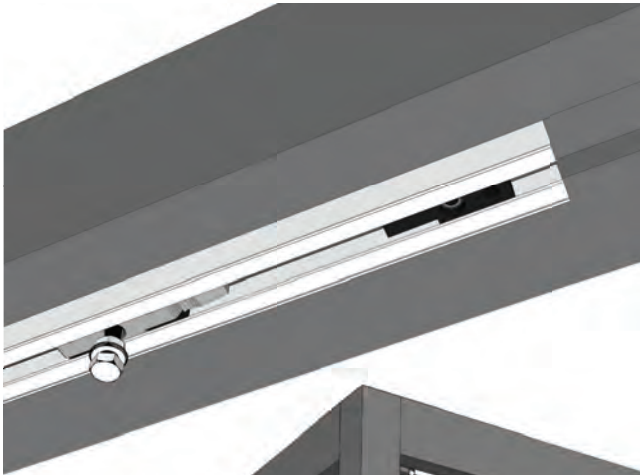

ALU dorpel bevestigen aan beton
Attacher le profil ALU sur le béton
Attach ALU profile to concrete

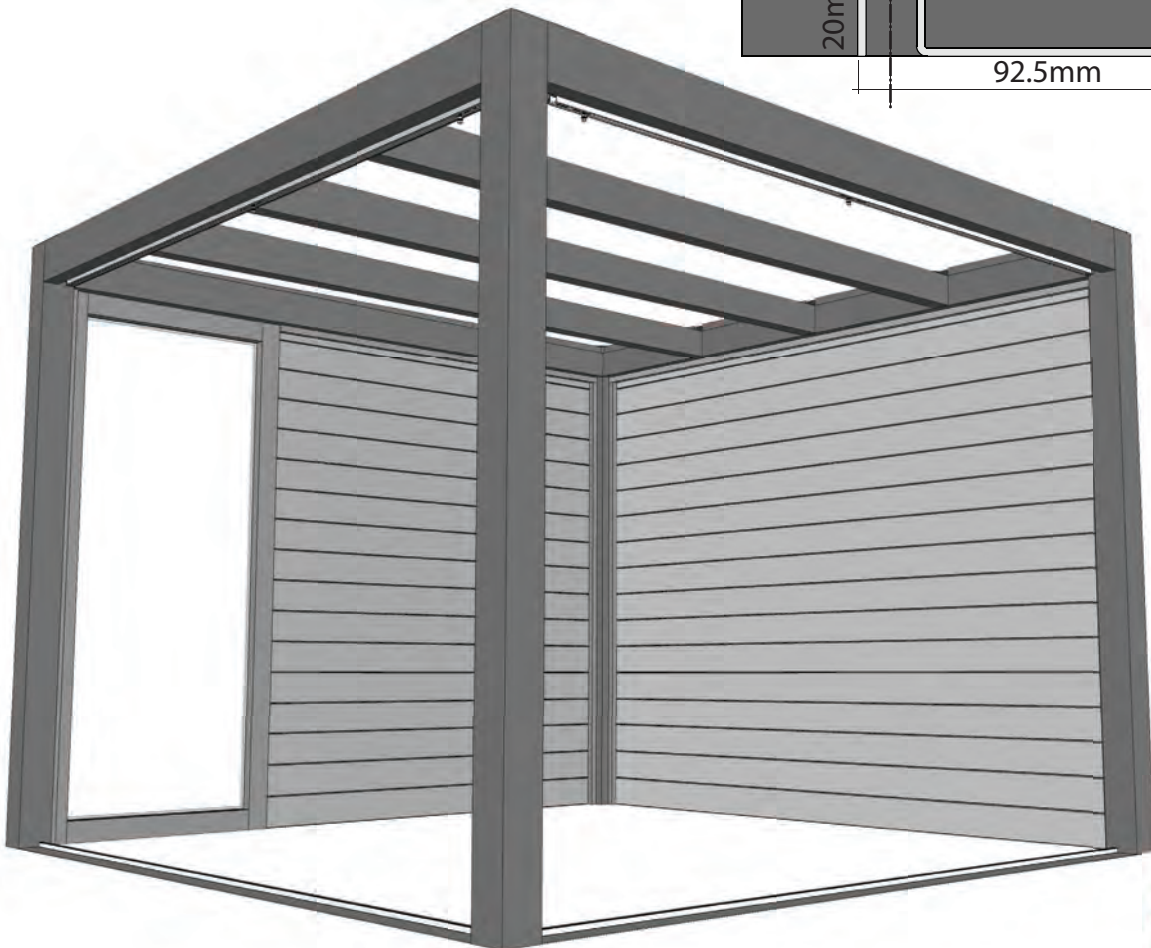
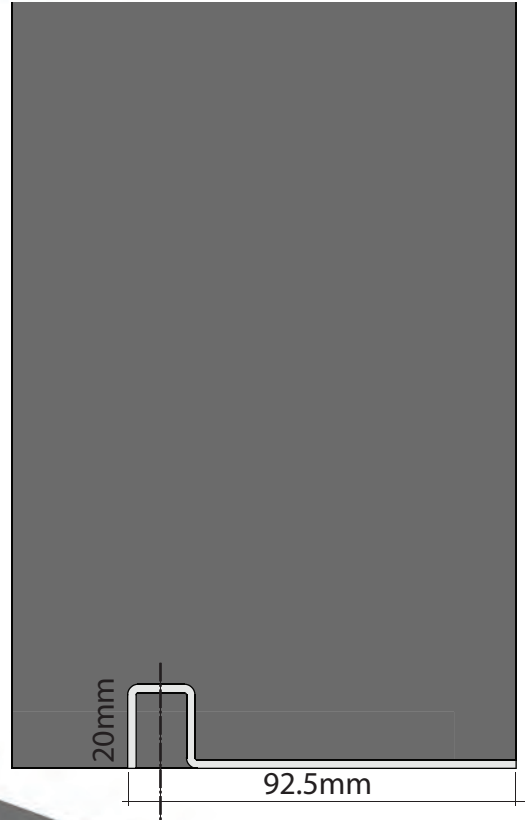
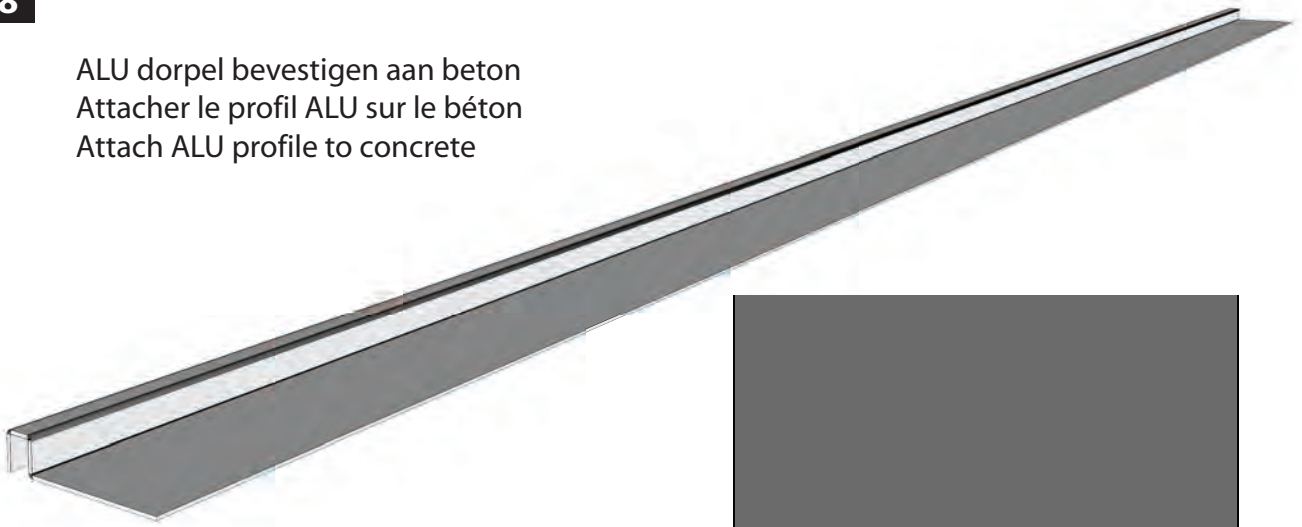

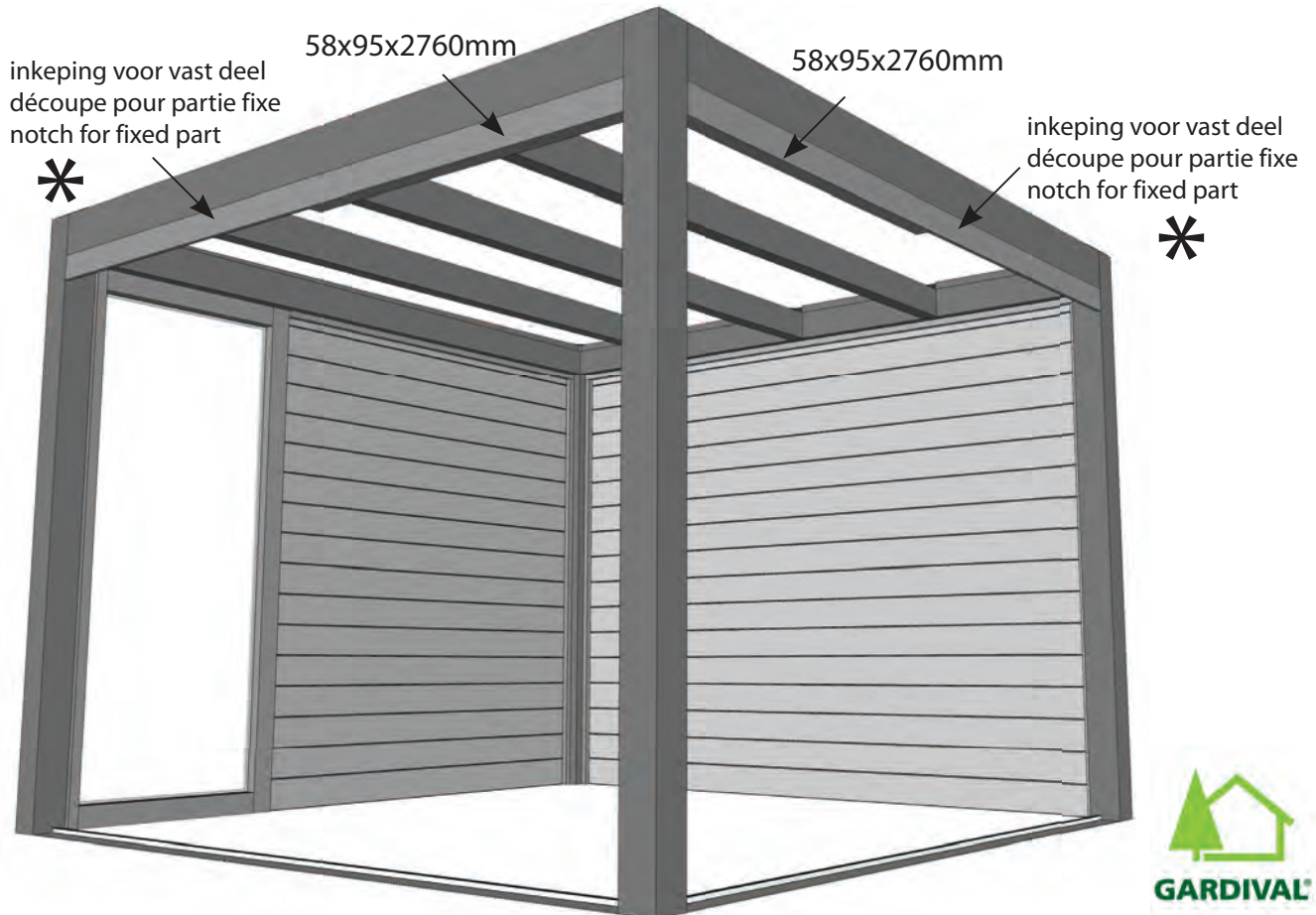
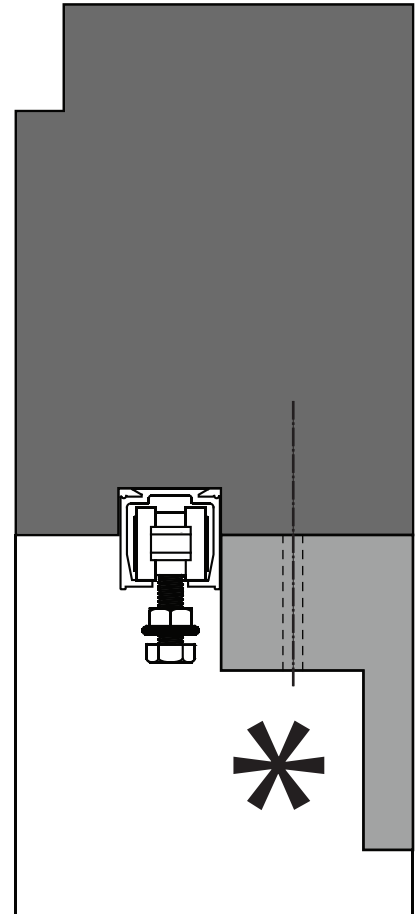
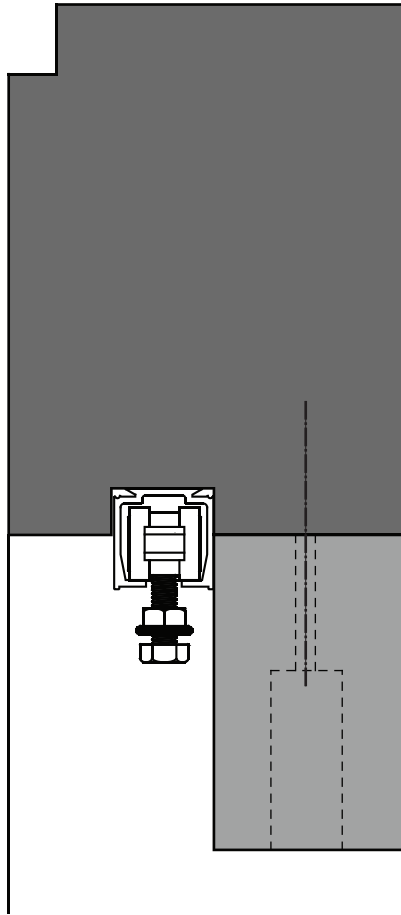

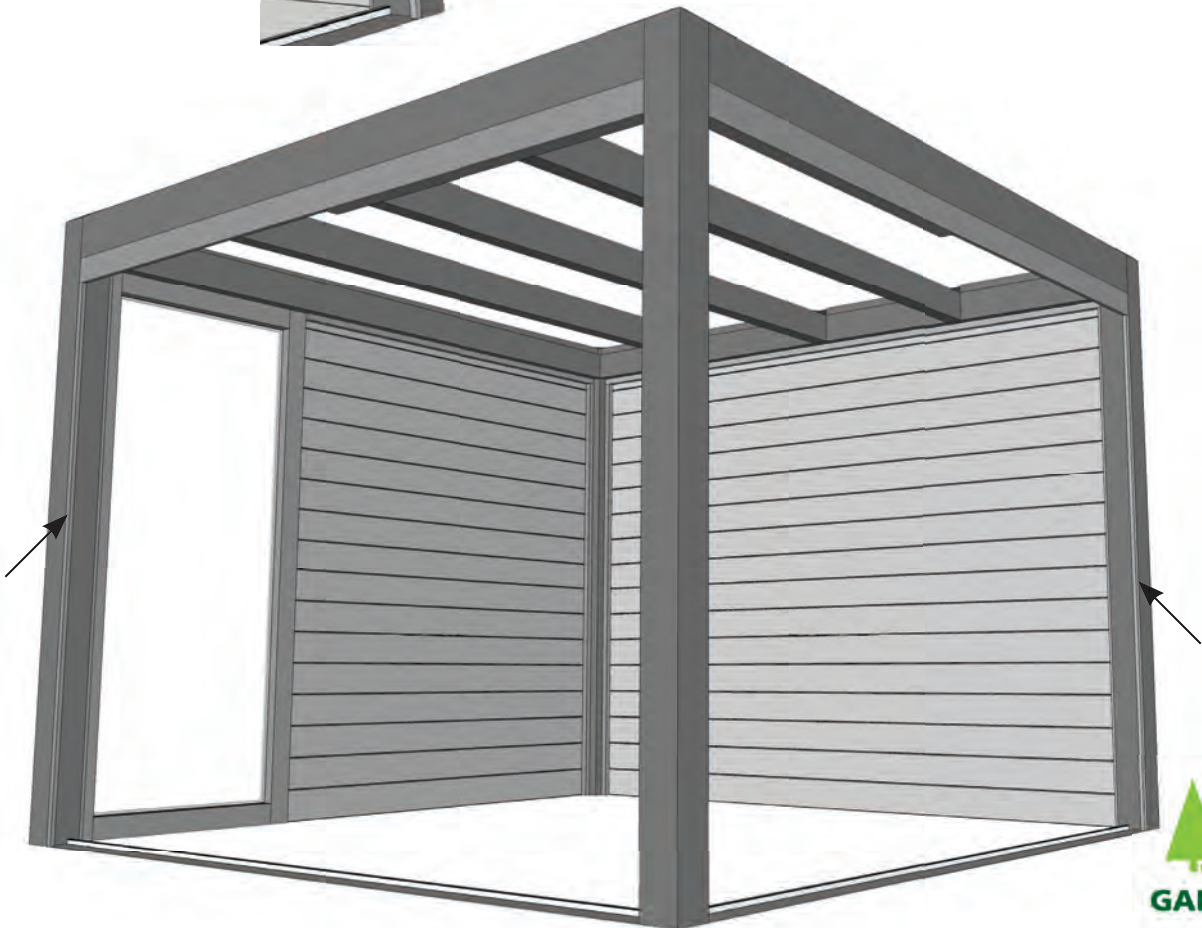
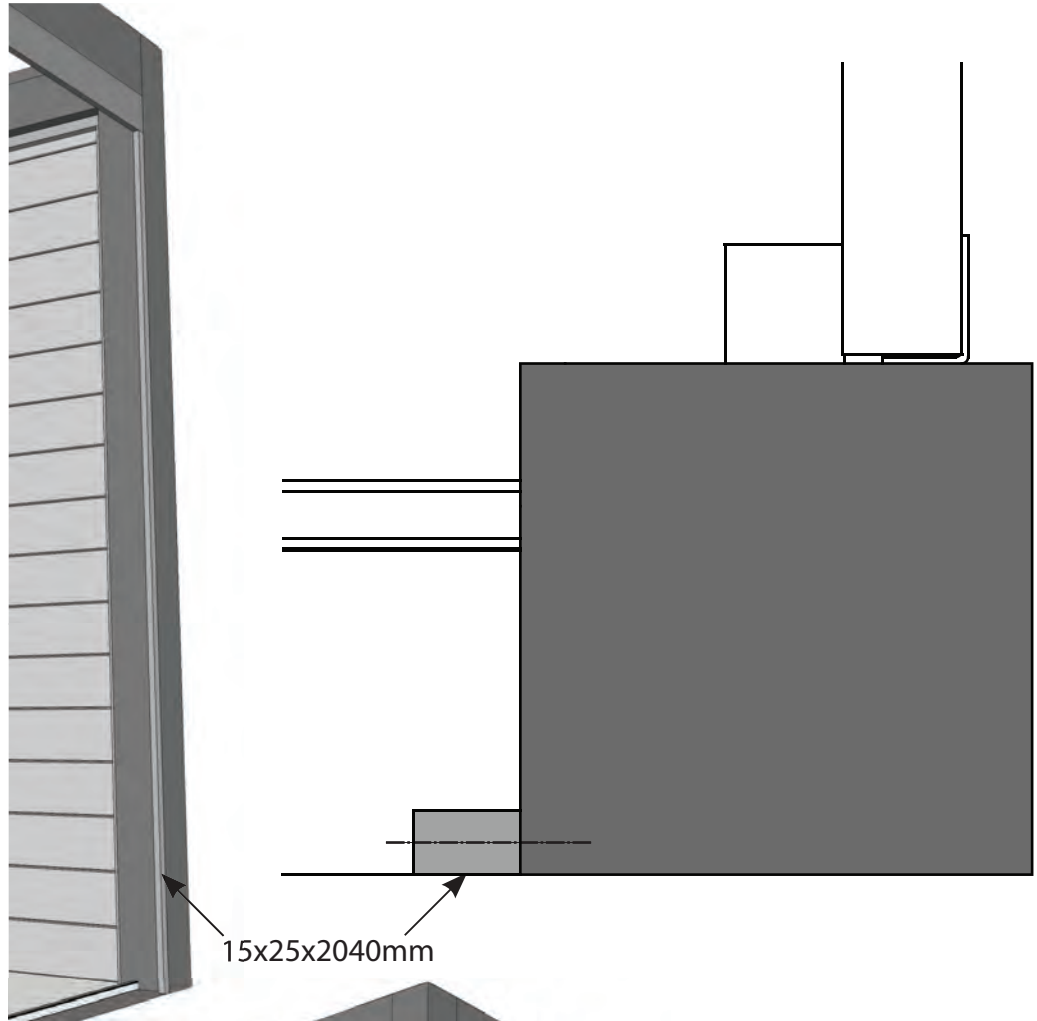
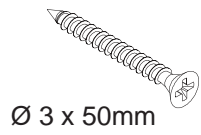

Lat 20x32x1420mm aan ALU dorpel en beton bevestigen.
Attacher un latte 20x32x1420mm sur le profil ALU et sur le béton
Attach a lath 20x32x1420mm to the ALU profile and concrete

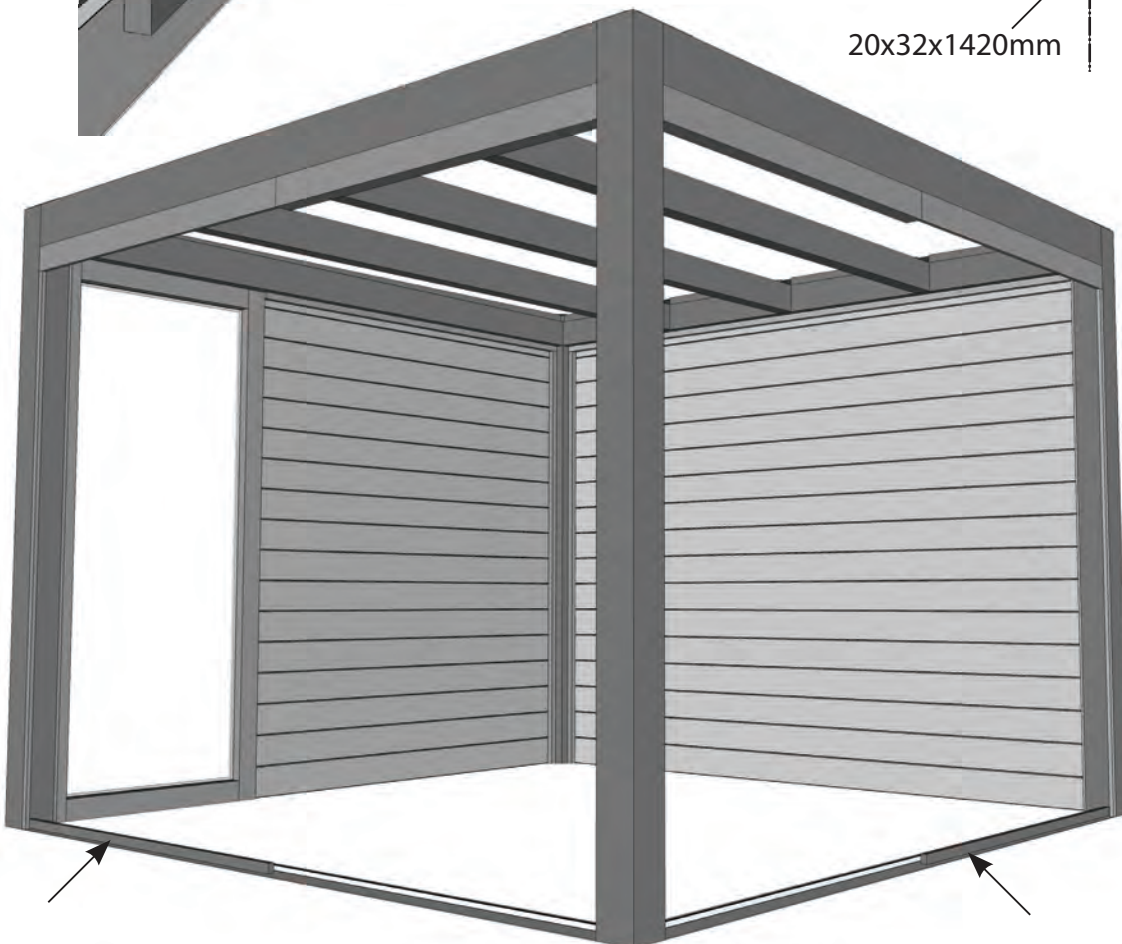
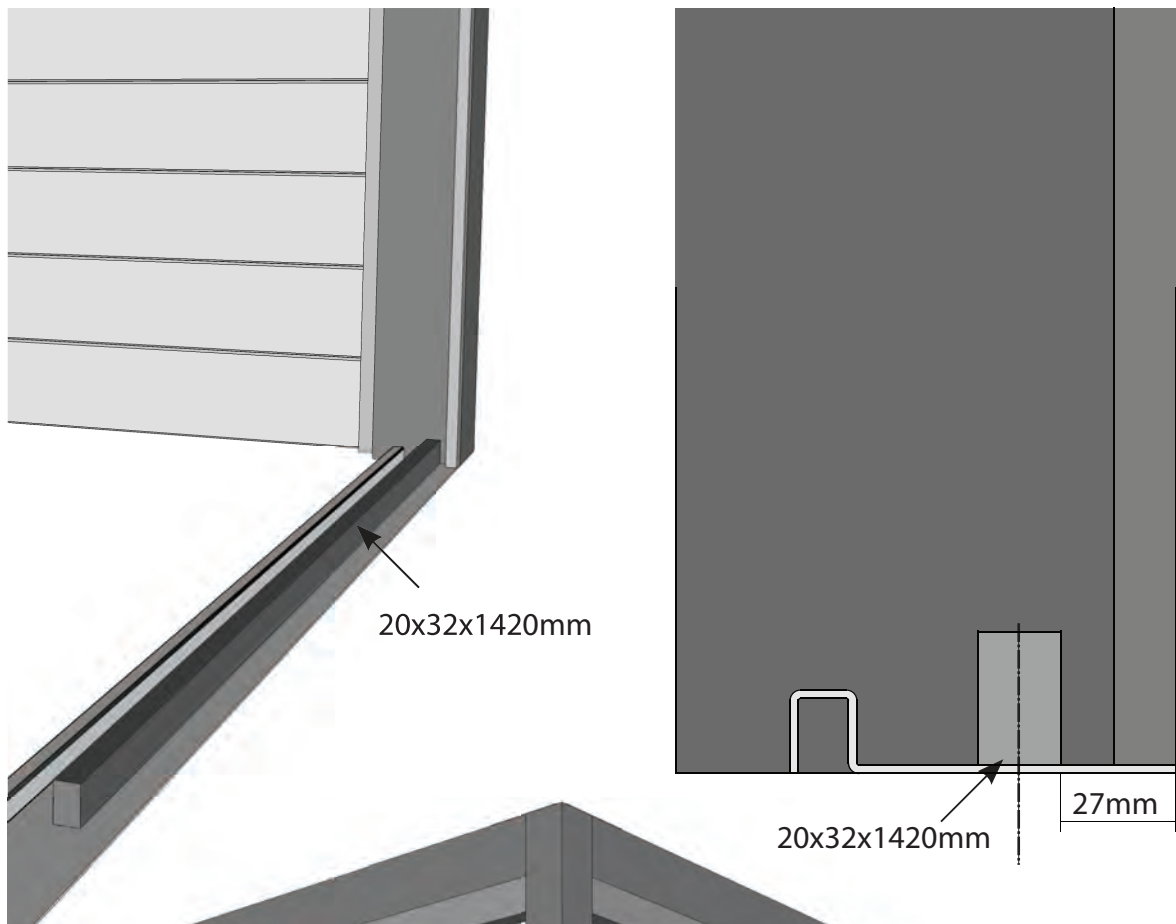

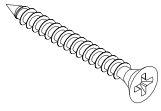

Ø 4 x 40mm INOX

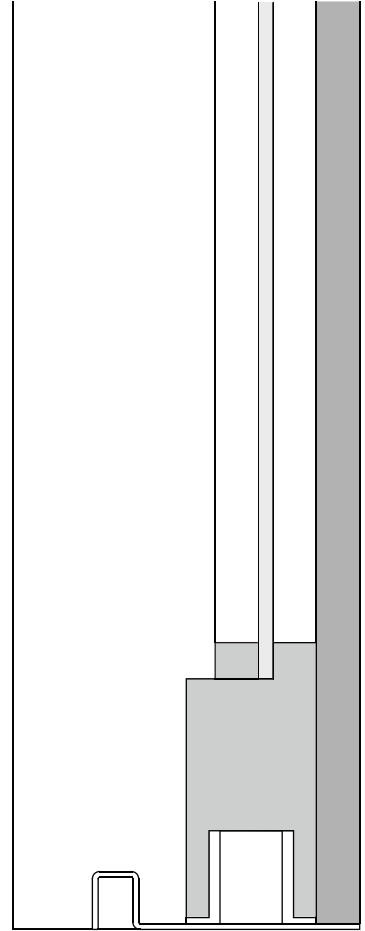
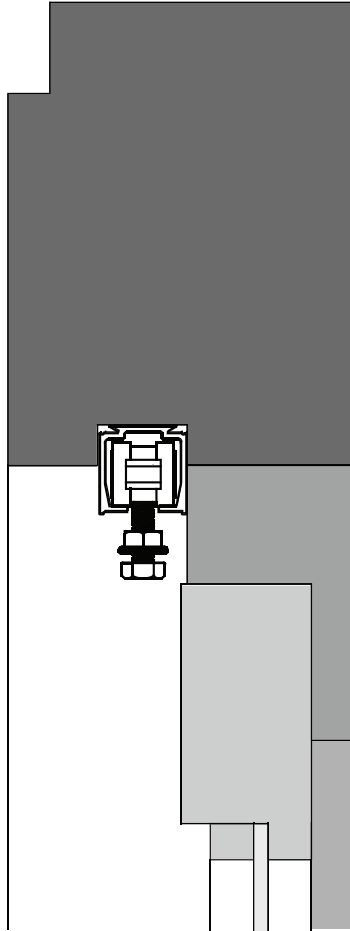
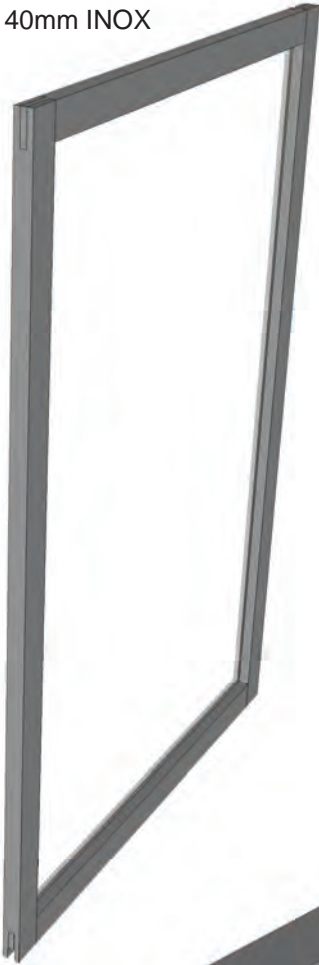

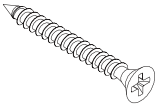

Ø 4 x 50mm INOX

28x58x2040mm

28x58x2040mm

28x58x2040mm



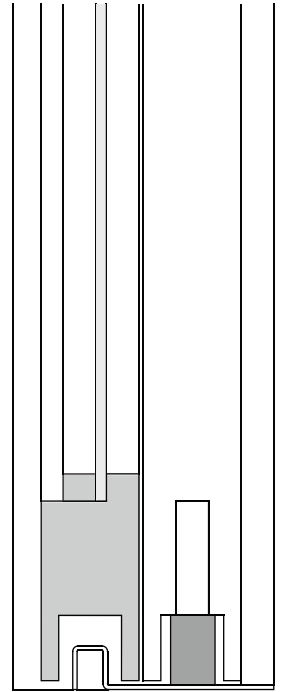
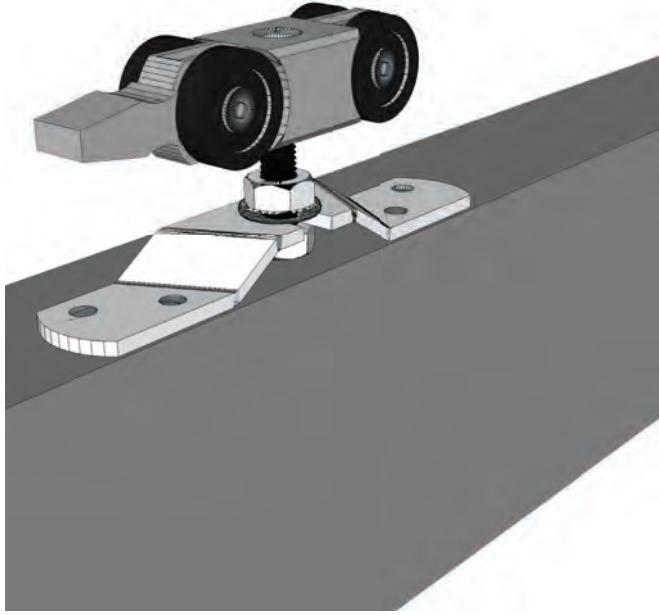
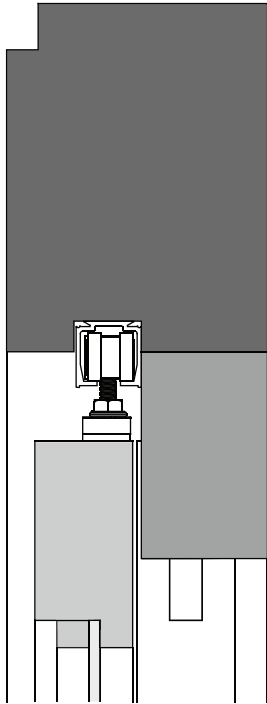

Plaatsing EPDM dakbedekking / Pose de la couverture de toit EPDM

Hieronder vindt u richtlijnen terug voor het installeren van de dakbedekking van uw tuinhuis.
 Veuillez trouver ci-après les instructions pour la mise en œuvre de la couverture de votre abri de jardin.

Belangrijk: Lees de instructies aandachtig vooraleer u met de plaatsing van start gaat!
 De installatie dient te gebeuren bij droge en vriesvrije weersomstandigheden.
 Important : Lisez attentivement les instructions avant de commencer l'installation!
 Les travaux seront effectués dans des circonstances de temps sec et absence de gel.

Vorbereitung / Préparation

- Het platte dak (helling <2%) dient vlak, egaal, droog en proper te zijn.
 Het dakoppervlak wordt daarvoor eerst afgeborsteld en nagekeken op eventuele uitstekende schroeven of onzuiverheden.
 Le toit plat (une déclivité inférieure à 2%) doit être lisse, sec et propre.
 Brossez bien la surface du toit et vérifiez qu'il n'y a plus d'inégalités (e.g. des aspérités dangereuses ou impuretés).
- De lijmen goed mengen voor gebruik (min. 1 à 2 min. goed mixen tot een homogeen mengsel)
 Veuillez bien mélanger les colles avant l'utilisation (min. 1 à 2 minutes afin d'obtenir un mélange homogène).

Materialen / Matériaux

Controleer of volgende producten zich in de kartonnen doos bevinden / Vérifiez bien que la boîte contient ce qui suit :

- EPDM folie / La feuille EPDM (1.15 mm) : 3.05 x 3.05m
 Smitbus met EPDM contactlijm / Aérosol avec colle de contact EPDM
- Aluminium hemelwaterafvoer met klemring / Tuyau de descente aluminium avec anneau de fixation
- Gereedschappen: Verroller, Mixerstaaf
 Outils : Rouleau à peinture, Mélangeur

Controleer of ook volgende zaken zijn bijgeleverd / Veuillez contrôler que vous trouviez également ce qui suit :

- Klokboor (zaag voor het maken van een ronde opening)
 Scie cloche (une scie pour créer une ouverture ronde)
- Schroeven / Vis
- Houten blokje / Petite pièce de bois

Voorts dient u zelf over volgende benodigdheden te beschikken: mes, schaar, schroevendraaier, veegborstel, hamer.
 Veuillez prévoir aussi les outils suivant : Couteau, Ciseaux, Tournevis, Brosse, Marteau

Installatie / Installation

1. Positionering EPDM folie / Application de la feuille EPDM

Benodigdheden / Les outils :

EPDM folie / La feuille EPDM

Uitvoering / Exécution :

- Het EPDM membraan wordt op de grond opgevouwen.
 - Dépliez la feuille EPDM au sol.
- Plaats de folie op het platte dak van uw tuinhuis en vouw deze open.
 - Repliez la feuille EPDM et positionnez-la sur le toit de votre abri de jardin.

